

# Helium Neon laser, basic set



Physics

Modern Physics

Atomic &amp; Molecular Physics

Applied Science

Engineering

Photonics

Lasers



Difficulty level

hard



Group size

2



Preparation time

10 minutes



Execution time

20 minutes

**PHYWE**  
excellence in science

## General information

## Application

**PHYWE**  
excellence in science

Helium-neon laser tube

Helium-neon lasers have been widely in industries, such as in:

- barcode scanners - to scan the universal barcodes to identify products
- surveying - fast laser pulse is sent to a corner reflector at the point to be measured and the time of reflection is measured to get the distance.
- laser disc - to read optical disk

## Other information (1/2)

**PHYWE**  
excellence in science

### Prior knowledge



Gas lasers are lasers that use one or a mixture of gases as gain medium, in which an electric current is discharged through the gain medium inside the laser medium to produce laser light. Helium-neon lasers are categorised as gas lasers whose gain medium consists of a mixture of 10:1 ratio of helium and neon and typically emit light with a wavelength of 632.8 nm. The helium gas in the laser tube provides the pumping medium to attain the necessary population inversion for laser action.

### Scientific principle



Basic properties of an open HeNe laser system such as amplifier behavior, resonator stability, output power and laser wavelength are explored and discussed. The influence of the resonator cavity on beam diameter and divergence is observed.

## Other information (2/2)

**PHYWE**  
excellence in science

### Learning objective



Understanding criteria and principles of Helium-Neon laser.

### Tasks



1. Adjusting and starting the HeNe laser system
2. Stability criteria of an optical resonator
3. Beam diameter and divergence in dependence on resonator properties
4. Laser output power in dependence on resonator properties
5. Laser output power in dependence on discharge current
6. Determination of the laser wavelength with an optical grating

## Safety instructions

**PHYWE**  
excellence in science

For this experiment the general instructions for safe experimentation in science lessons apply.

For H- and P-phrases please consult the safety data sheet of the respective chemical.

Never touch nor scratch any of the optical surfaces like windows or mirrors!

Handle the optical components with care! Never touch a dielectric mirror surface with fingers and keep the optical surfaces clean. Cleaning has to be done with acetone and special lens cleaning tissue. For cleaning refer to the operation manual.

## Theory (1/54)

**PHYWE**  
excellence in science

### *Introduction*

Laser is the acronym for light amplification by stimulated emission of radiation. Normally lasers are understood to be sources of coherent radiation of low divergence thus to be spontaneous oscillators. But an amplifier alone does not make an oscillator.

Back feeding brings an amplifier to oscillate spontaneously. If the back feeding is broad-banded in frequency, the amplifier will then oscillate with the frequency of its maximum gain. If the gain profile over frequency of the amplifier has several maximums, the behavior depends on the principle of the energy supply of the amplifier to an existing oscillation.

Any back feed oscillation will reach the output level where the amplifier reaches saturation, i.e. where the amplifying process can not supply more energy to that oscillation.

## Theory (2/54)

### *Homogenous and heterogenous gain profile*

If the energy is supplied to different frequencies by different paths, several frequencies may oscillate simultaneously. In this case the corresponding gain profile is referred to as inhomogeneous gain profile. Else the oscillation with the greatest gain will take all the energy provided by the amplifier and the gain profile is called homogeneous.

The back feeding system of the HeNe laser is an optical resonator which has a very pronounced frequency response and needs closer examination. So the oscillations occurring in the HeNe laser system depend on both the properties of amplifier and resonator.

The total gain, the product of both amplifier gain for a given frequency and resonator quality factor for that frequency, determines the system's behavior at that frequency.

## Theory (3/54)

### *Stimulated emission*

The amplifier of the HeNe laser system, the laser in strict sense, is a DC low pressure gas discharge in a glass tube of 1 mm diameter. Amplification of incoming light occurs when an incoming photon's frequency matches the frequency of an optical transition with population inversion and provokes an electron of the more densely populated upper state of that transition to decay to the less populated lower state of that transition under emission of a photon of the same quantum state as the incoming photon. This is called stimulated emission. The amplifier saturates when for that transition the rate of stimulated emission reaches the filling process rate of the upper state that provides for the population inversion of that transition.

## Theory (4/54)

**PHYWE**  
excellence in science

### *Creation of population inversion in the HeNe gas discharge: – Collisions types*

In thermodynamic equilibrium a population inversion is impossible so the process leading to population inversion in a HeNe gas discharge needs explanation: The gas discharge is a plasma, part of the atoms are ionized. The ions and electrons are accelerated in the electric field and lose the energy extracted from the field in collisions with the neutral atoms and the capillary walls.

Partly the scattering on the neutral atoms is inelastic converting some of the impact energy in electron excitation of the collision partners. So also the neutral atoms in the gas discharge get excited, mainly by electrons.

Excitation energy of one atomic species may be transferred to another during a collision with a high probability if the excitation energy of the first species matches an excited state of the other. Inelastic collisions where part of the impact energy is converted to internal degrees of freedom are referred to as collisions of the second type.

## Theory (5/54)

**PHYWE**  
excellence in science

### *He and Ne excited states*

The gas mixture in the gas discharge consists of 80 % Helium and 20 % Neon. Helium atoms with their two electrons can be in a singlet state with electron spins antiparallel or in a triplet state with electron spins parallel. The Helium excited states with lowest excitation energy,  $2^3S_1$  with 19.820 eV and  $2^1S_0$  with 20.616 eV compared to the ground state  $1^1S_0$ , are metastable. They may not decay optically to  $1^1S_0$  because transitions between S-levels are forbidden for all electromagnetic forms of radiation. So the Helium atoms excited by electron collision exist to a good fraction in the metastable excited states.

The metastable Helium excited states decay through collision with the capillary wall or through collisions with other atoms. In case of collision with Neon atoms the following happens: The  $2^1S_0$  state with 20.616 eV of Helium easily transfers its energy to a ground-state Neon atom exciting it to the electronic configuration  $2S^2 2p^5 5s$ .

## Theory (6/54)

This configuration exists with four sub-states, of which mainly the upper one with 20.663 eV is populated in this sort of collision. The excess energy of 47 meV is provided by thermal energy  $kT$ . The  $2^3S_1$  state of Helium with 19.820 eV transfers its energy to one of the four  $2s^2 2p^5 4s$  configurations of Neon with energies of 19.664, 19.688, 19.761 and 19.780 eV. These processes efficiently lead to Neon excitation and Helium deexcitation.

The Neon excited  $5s$  and  $4s$  states decay to  $2s^2 2p^5 3p$  configurations. These decays are the laser transitions used in HeNe laser systems.

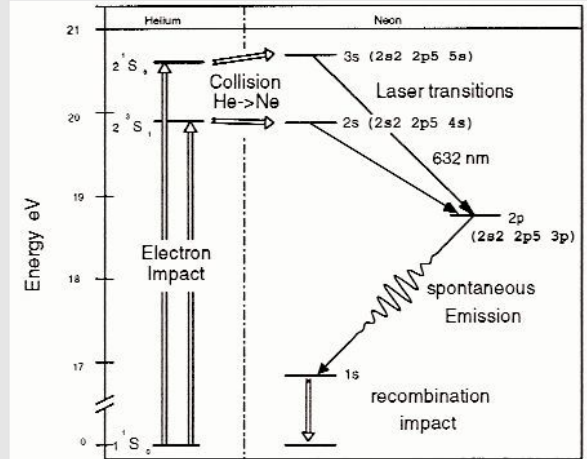

Neon excitation scheme

## Theory (7/54)

The lifetime of the Neon  $5s$  and  $4s$  states is ten times longer than that of the  $3p$  states that decay to metastable  $2s^2 2p^5 3s$  emitting ultraviolet light. So if the  $5s$  and  $4s$  states are populated by collisions of the second type, a population inversion occurs. The  $5s - 3p$  decay emits in the visible region and the  $4s - 3p$  decay emits in the near infrared. The emptying of the  $2s^2 2p^5 3s$  levels to ground state  $2s^2 2p^6$  is optically forbidden and has to be effected by collisions with the capillary wall. This process may be a bottleneck to the laser process because population inversion is only feasible if the lower laser levels gets emptied fast enough.

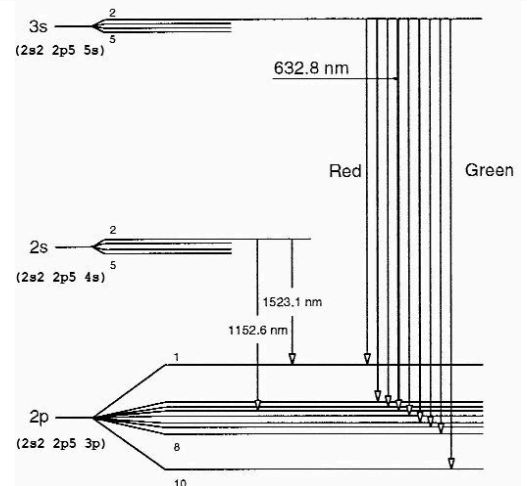

Laser transitions

## Theory (8/54)

So the capillary size has to be a compromise: A wider size allows for a greater active medium's volume but the ratio wall surface for deexcitation to active medium volume gets lower for a wider diameter thus limiting laser power, too.

### *Gain profile over frequency of the optical amplifier*

So the gain profile of the HeNe optical amplifier consists of all the Neon transition lines where collisions of the second type between Helium and Neon have effected population inversion. These transitions are all in the infrared and visible range. Each of the transition lines has a natural linewidth due to lifetime of the higher level and a line broadening caused by Doppler effect due to atom speed distribution in the line of sight. Since here the Doppler linewidth is considerably greater than the natural linewidth, sets of atoms with different speed can be discerned and interact separately with the radiation field. An interaction with light of a specific frequency will only alter the population inversion of a set of atoms with the corresponding speed. Thus the gain profile is inhomogeneous.

## Theory (9/54)

### *Amplifier efficiency*

It should be kept in mind that the overall energy conversion from electric energy from the plasma to laser light is principally inefficient: Many atomic excitations may decay by incoherent light emission and the process of Neon excitation is complex and many inelastic scattering processes lead only to capillary wall heating.

In the laser process only one of several transitions with population inversion is used. And of the approx. 20 eV Neon excitation energy only 2 eV are used for the visible laser transition. So the efficiency of HeNe lasers does not exceed the  $1/10^{th}$  per cent rate.



## Theory (10/54)

**PHYWE**  
excellence in science

### *Other laser tube characteristics, Polarization of the laser light*

Photons can be distinguished not only by their wavelength but also by their polarization and the spatial distribution of their detection probability. Principally the sensitivity of the atoms in the gas discharge is isotropic for all possible polarizations.

The atom's velocity distribution is nearly isotropic, too. So a volume element of the gas discharge has an spatially isotropic gain. But the gas discharge's geometry is a lengthy cylinder along the capillary leading to an enhanced gain along the capillary's axis compared to any other direction

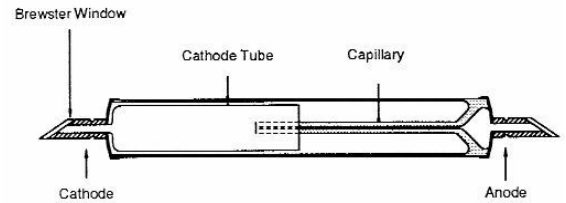

Laser tube scheme

## Theory (11/54)

**PHYWE**  
excellence in science

Additionally the gas discharge has to be confined from the surrounding atmosphere. Since a gas discharge has a low density, the optical gain is altogether quite low (some % per meter). So reflection on the laser tube's confinement has to be avoided.

This is done by optical windows in the Brewster angle which have zero reflection for a specific polarization but do have reflection losses for any other polarization. Thus the laser tube's gain depends on polarization and a HeNe laser beam of a laser tube with Brewster windows is fully linearly polarized.

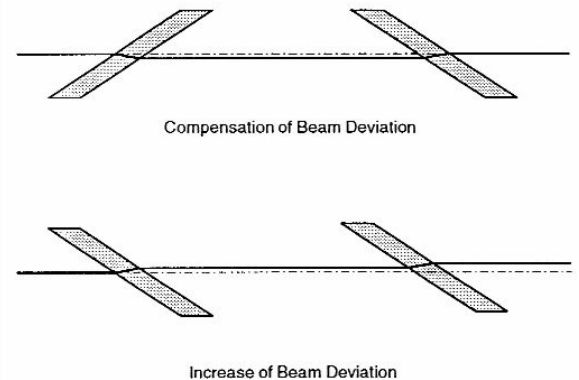

Brewster window orientation

## Theory (12/54)

### *Gain profile of the feedback system*

Usually the optical cavity for a HeNe laser is a Fabry-Perot resonator (or: interferometer) consisting of two opposite mirrors with the laser tube in between. The transmission of a Fabry-Perot resonator is a frequency comb with spikes that are equidistant in frequency and the frequencies of which are integer multiples of the first natural frequency. The height of the spikes is modulated over frequency with the mirror's frequency-dependent reflectivity.

Here the feedback for the optical amplifier is high in case of the same interference conditions that lead to a high transmission of the Fabry-Perot resonator, i.e. when a standing continuous wave is established inside the resonator and the amplifier's output is coupled back into the amplifier with correct phase.

Since the gain of the laser tube is low, the mirrors must have a high reflectivity to make spontaneous oscillation possible. Spontaneous oscillation is also referred to as laser ignition or lasing condition. So the Fabry-Perot resonator is of high quality and fineness.

## Theory (13/54)

### *Fineness*

The fineness or quality factor is a measure for the ratio of full width at half maximum (FWHM) of one peak to frequency distance of two adjacent peaks or in other words the frequency resolution of the Fabry-Perot resonator.

### *Natural frequencies of a Fabry-Perot cavity*

Natural frequencies between two mirrors with spacing  $d$  in between occur, when the phase after passing the whole optical pathway  $2d$  is the same again, i.e. integer multiples  $2\pi$  of corresponding to a wavelength  $\lambda$ .  
 So

$$2d = n \cdot \lambda = n \cdot \frac{c}{f} \quad \text{or} \quad f = n \cdot \frac{c}{2d}$$

with  $n$  an integer  $> 0$ , speed of light  $c$  and  $f$  the light's frequency.

## Theory (14/54)

### *Resonator modes combined with amplifier gain*

With  $n = 1$ ,  $d = 0.5 \text{ m}$ ,  $c = 3 \cdot 10^8 \text{ m/s}$  is  $f = 300 \text{ MHz}$  the frequency distance of adjacent resonator modes while the frequency of the red 633 nm visible HeNe laser light is  $4.7 \cdot 10^{14} \text{ Hz} = 470 \text{ THz}$ , making an  $n$  in the range of 1.6 million. The Doppler linewidth would be here about 1.5 GHz FWHM so several resonator modes would be inside the line's gain profile. A short resonator length reduces the possible number of modes and a usual 5" = 127 mm resonator length laser runs in a single resonator mode.

A photon state in a resonator is fully defined by the resonator mode it belongs to. So far only longitudinal resonator modes have been discussed here but there may also be transversal modes in a Fabry-Perot resonator depending on mirror curvature, diameter and distance. Several transversal modes at nearly the same energy may belong to a single longitudinal mode number. The transversal mode numbers are usually low one digit integers while the longitudinal mode number is in the millions and never actually determined. The stable resonator modes are to be discussed later on.

## Theory (15/54)

### *Airy function*

The peak form of the resonator is given by the Airy-function for the transmission of the resonator, the transmission again being a measure for the back feeding capability of the resonator

$$\frac{I}{I_0} = \frac{(1-R^2)}{(1-R^2) + 4 \cdot R \cdot \sin^2\left(\frac{2\pi}{\lambda \cdot d}\right)}$$

where  $I$  denotes the intensity and  $R$  is the reflectivity of the mirrors. The higher the reflectivity, the sharper get the peaks. If the mirrors do not have the same reflectivity but have the reflectivity  $R_1$  and  $R_2$ , then the geometric mean value of the reflectivities does apply

$$R = \sqrt{R_1 \cdot R_2}$$

## Theory (16/54)

### *Properties of the mirrors*

The reflectivity of a mirror is always a function of light frequency,  $R = R(f)$ , but the variations in  $R$  are long-ranged compared to the frequency distance of adjacent longitudinal resonator modes or transition line widths.

For acquiring the high reflectivity needed for HeNe laser operation, dielectric mirrors are used. Dielectric mirrors like interference filters consist of a sequence of layers of alternating high and low refractive index. Here layer thickness is tuned to constructive interference of the Fresnel-reflected light from the layer surfaces. A precise match exists only for discrete frequencies. Due to the fact that the layers are thin and usually contain only one quarter of the design wavelength, the reflectivity is high for a whole frequency range, still it is frequency dependent. A high reflective mirror for visible light is usually not high reflective in the near infrared. So the laser system in use here may operate at several visible transitions but is not suitable for infrared operation, though the laser tube's gain is principally higher in the infrared range.

## Theory (17/54)

### Task 2

For optical cavity analysis usually a stability factor  $g$  is introduced comprising the ratio of resonator length  $d$  to radius of mirror curvature  $r = 2f$  with

$$g_i = 1 - \frac{d}{r_i} = 1 - \frac{d}{2f_i}$$

The stability criterion for a laser resonator to be derived later on is

$$0 \leq g_1 g_2 \leq 1$$

Here, mirror radius is positive with concave mirrors and negative with convex mirrors as seen from the inner of the resonator cavity.

## Theory (18/54)

**PHYWE**  
excellence in science

In this experiment stability was tested for three combinations of mirror curvature:

1.  $r_1 = \infty, r_2 = 1000 \text{ mm}, g_1 = 1, g_2 = 1 - d/1000 \text{ mm}$
2.  $r_1 = \infty, r_2 = 1400 \text{ mm}, g_1 = 1, g_2 = 1 - d/1400 \text{ mm}$
3.  $r_1 = 1000 \text{ mm}, r_2 = 1400 \text{ mm}, g_1 = 1 - d/1000 \text{ mm}, g_2 = 1 - d/1000 \text{ mm}$

In this laser set up the mirror distance  $d$  is at least the laser tube length of 420 mm and at most with both mirror holders facing right and the holders protruding each 10 mm from the rail 1465 mm.

## Theory (19/54)

**PHYWE**  
excellence in science

Figure plots the stability criterion  $g_1 \cdot g_2$  over mirror distance  $d$ . Each shown curve corresponds to a special resonator geometry. The stability criterion is fulfilled as long as the curves lie in the area defined by the  $[0,1]$  interval on the y-axis and the whole x-axis.

For one flat and one curved mirror the stability criterion is linear in  $d$  and the graph is steeper for the smaller radius of curvature  $r$ . So with smaller radius of curvature the region of stability gets smaller and is of the size of the radius of curvature. For two curved mirrors the stability criterion is a parabola. If the radii are not equal this results in two regions of stability that are separated by a region of instability of the size of the difference of the radii.

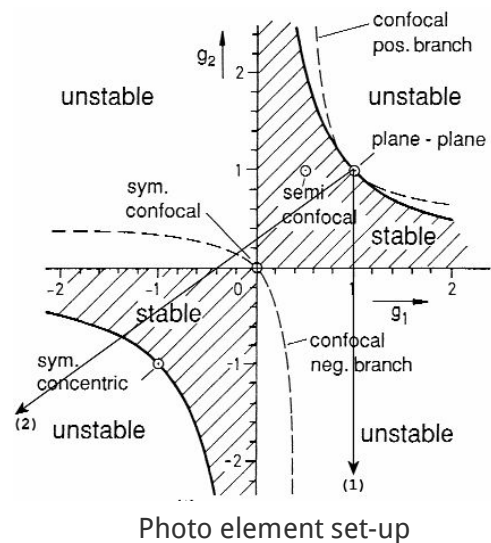

## Theory (20/54)

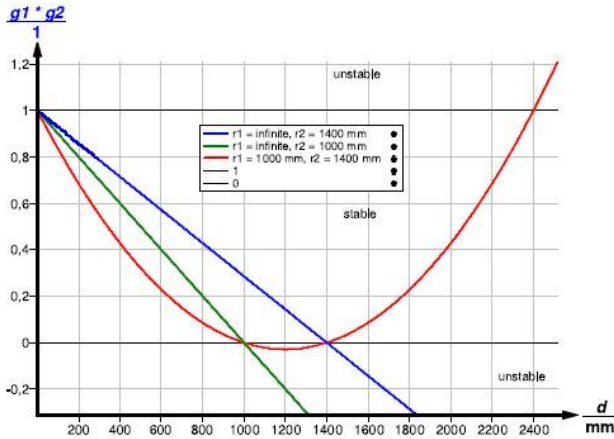

Stability criterion  $g_1 \cdot g_2$  over mirror spacing  $d$

If one mirror was convex and the other concave, the graph would be a parabola that opens downwards and starts at unity for  $d = 0$ . The stability criterion can also be represented in the  $g_1 - g_2$  plane as shown in the figure. The areas in the plane where the stability criterion is fulfilled are shaded. With a flat - concave resonator one travels along arrow (1) in the  $g_1 - g_2$  plane starting from (1; 1) when increasing mirror spacing  $d$  from zero. With the 1000 mm - 1400 mm concave - concave resonator is the journey along arrow (2)

## Theory (21/54)

Type	Mirror radius	Stability parameter
Confocal	$b_1 + b_2 = 2d$	$g_1 + g_2 = 2g_1g_2$
Concentric	$b_1 + b_2 = d$	$g_1g_2 = 1$
Symmetric	$b_1 = b_2$	$g_1 = g_2 = g$
Sym. confocal	$b_1 = b_2 = d$	$g_1 = g_2 = 0$
Sym. concentric	$b_1 = b_2 = 1/2d$	$g_1 = g_2 = -1$
semi confocal	$b_1 = \infty, b_2 = 2d$	$g_1 = 1, g_2 = 1/2$
plane	$b_1 = b_2 = \infty$	$g_1 = g_2 = 1$

Some special types of resonators

The stability criterion is to be derived in the following: To examine the stability of the optical resonator the behavior of a ray in the sense of geometrical optics after a round trip in the resonator is determined.

The resonator is to consist of a left mirror with focal length  $f_1$  and radius of curvature  $r_1 = 2 f_1$  and a right mirror with focal length  $f_2$  and radius of curvature  $r_2 = 2 f_2$ .

## Theory (22/54)

The  $z$ -axis is to show to the right and the  $x$ -axis is to point upwards. The left mirror is situated at  $z = 0$  and the right at  $z = d$ .  $f_i$  and  $r_i$  are considered positive for concave and negative for convex mirrors as seen from the inner of the resonator ( $0 \leq z \leq d$ ).

Because of rotation symmetry of the resonator the azimuth angle of the ray is omitted and only rays in a plane with the optical axis are considered. This may not be done for detailed mode examination of diffraction limited beams that are described with Hermite polynomials as intensity distribution.

Let's consider a geometrical ray starting at the left mirror  $S_1$  with an arbitrary initial angle  $\theta_i$  to the optical axis and an arbitrary distance to the optical axis  $x_i$ .  $x_i$  is considered small enough so that imaging rules apply.  $\theta_i$  should be reasonably small such that  $\sin \theta_i \approx \theta_i$  holds. After passing the distance  $d$  the ray impinges upon the right mirror  $S_2$ . The angle is still  $\theta_i$  but the distance to the optical axis is now

$$x'_i = x_i + d \cdot \theta_i$$

## Theory (23/54)

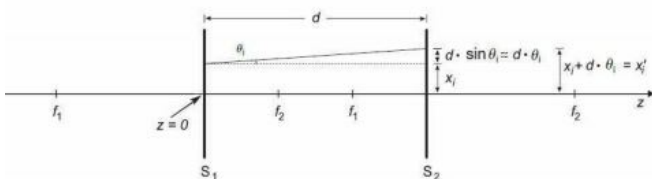

Ray starting from left mirror to the right

After reflection,  $x'_i$  is unchanged but the angle is now with

$$f_2 \cdot \theta'_i = x'_i - f_2 \cdot \theta_i \quad ;$$

$$\theta'_i = \frac{x'_i}{f_2} - \theta_i \quad ,$$

thus

$$\theta'_i = \frac{x_i + d \cdot \theta_i}{f_2} - \theta_i = \frac{x_i}{f_2} + \left( \frac{d}{f_2} - 1 \right) \theta_i$$

## Theory (24/54)

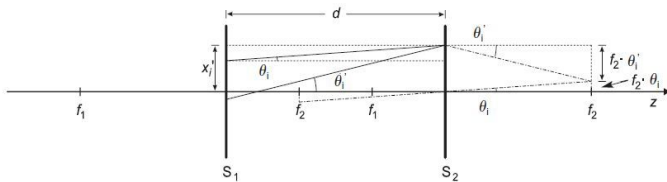

Ray reflected from the right mirror

Now the beam travels in the other direction along the distance  $d$  with the angle  $\theta'_i$ , thus a negative sign with  $d$ . While the angle is constant the distance from the axis changes from  $x'_i$  to finally

$$x_f = x'_i - d \cdot \theta'_i = x_i + d \cdot \theta'_i - d \cdot \left( \frac{x_i}{f_2} + \left( \frac{d}{f_2} - 1 \right) \theta_i \right) \quad (1)$$

$$x_f = \left( 1 - \frac{d}{f_2} \right) x_i + \left( 2d - \frac{d^2}{f_2} \right) \theta_i$$

## Theory (25/54)

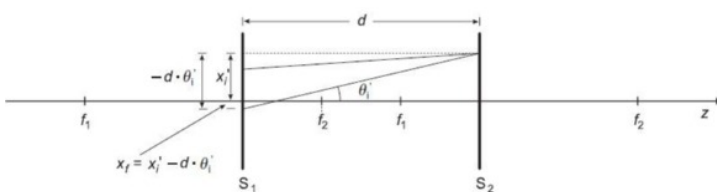

Distance of the ray to the optical axis when arriving on the left mirror again

To complete the round trip, the final angle after reflection on the left mirror has to be accounted for

$$f_1 \cdot \theta_1 = -f_1 \theta'_i - x_f \quad (2)$$

$$\theta_f = -\theta'_i - \frac{x_f}{x_f} =$$

$$= -\frac{1}{f_2} x_i - \left( \frac{d}{f_2} - 1 \right) \theta_i -$$

$$\left( \frac{1}{f_1} - \frac{d}{f_1 f_2} \right) x_i - \left( \frac{2d}{f_1} - \frac{d^2}{f_1 f_2} \right) \theta_i$$



## Theory (26/54)

In geometric optics in the plane of the optical axis a beam is completely described by its  $x$ - and  $\theta$ - values, they are coordinates to describe the beam. After one round trip in the resonator the initial values  $x_i$  and  $\theta_i$  are mapped onto the final values  $x_f$  and  $\theta_f$  by a transformation  $\overline{\overline{M}}$

The set of linear equations (1) and (2) define this transformation:

$$\overline{\overline{M}} = \begin{pmatrix} x_i \\ \theta_i \end{pmatrix} \rightarrow \begin{pmatrix} x_f \\ \theta_f \end{pmatrix}$$

$$\begin{pmatrix} x_i \\ \theta_i \end{pmatrix} \rightarrow \begin{pmatrix} (1 - \frac{d}{f_2}) & (2d - \frac{d^2}{f_2}) \\ (\frac{d}{f_1 f_2} - \frac{1}{f_1} - \frac{1}{f_2}) & (1 - \frac{2d}{f_1} - \frac{d}{f_2} + \frac{d^2}{f_1 f_2}) \end{pmatrix} \cdot \begin{pmatrix} x_i \\ \theta_i \end{pmatrix}$$

## Theory (27/54)

Stability analysis of the resonator means to find conditions where finite eigenvalues exist for this transformation iterated  $n$  times. Since the eigenvalue  $\lambda_n$  of the  $n$ -times iterated transformation equals the  $n$ -th power of the (in general) complex eigenvalue  $\lambda = \lambda_1$  of the transformation, i.e. the relation  $\lambda^n = \lambda_1^n = \lambda_n$  is valid, it is sufficient to investigate the eigenvalues of the transformation. So it has to be evaluated where the eigenvalue equation

$$\overline{\overline{M}} \begin{pmatrix} x_i \\ \theta_i \end{pmatrix} = \lambda \begin{pmatrix} x_f \\ \theta_f \end{pmatrix}$$

, or else

$$(\overline{\overline{M}} - \lambda \cdot \overline{\overline{I}}) \cdot \begin{pmatrix} x_i \\ \theta_i \end{pmatrix} = 0$$

## Theory (28/54)

with  $\bar{I}$  the 2 x 2 identity matrix

$$\begin{pmatrix} 1 & 0 \\ 0 & 1 \end{pmatrix}$$

has solutions for  $\lambda$  with absolute value 1 (if the absolute value is unequal 1,  $\ln \lambda^n$  goes to infinity or to zero with increasing n).

Eigenvalues exist if  $\det(\bar{M} - \lambda \cdot \bar{I}) = 0$

so the characteristic equation  $\lambda^2 - \text{tr}(\bar{M})\lambda + \det(\bar{M}) = 0$

## Theory (29/54)

has to be solved for  $\lambda$  with trace of a matrix the sum of the diagonal elements,

$$\text{tr}(\bar{A}) = \sum a_{ii} ,$$

$$\text{tr}(\bar{M}) = 2 - \frac{2d}{f_1} - \frac{2d}{f_2} + \frac{d^2}{f_1 f_2}$$

and the determinant of a 2 x 2 matrix  $\det(\bar{A}) = a_{11} \cdot a_{22} - a_{12} \cdot a_{21}$ , so here

$$\det(\bar{M}) = 1$$

(which you may prove as an additional task) thus

## Theory (30/54)

$$\lambda^2 - \left(2 - \frac{2d}{f_1} - \frac{2d}{f_2} + \frac{d^2}{f_1 f_2}\right) \lambda + 1 = 0$$

Usually a stability factor  $g$  is introduced comprising the ratio of resonator length  $d$  to radius of mirror curvature  $r = 2f$  with

$$g_i = 1 - \frac{d}{r_i} = 1 - \frac{d}{2f_i}, \text{ so that}$$

$$g_1 g_2 = 1 - \frac{d}{2f_1} - \frac{d}{2f_2} + \frac{d^2}{4f_1 f_2}$$

and the characteristic equation becomes

$$\lambda^2 - (4g_1 g_2 - 2) \lambda + 1 = 0$$

## Theory (31/54)

This quadratic equation is solved by

$$\lambda = (2g_1 g_2 - 1) \pm \sqrt{(2g_1 g_2 - 1)^2 - 1}$$

with  $g_i$  real numbers. The eigenvalue  $\lambda^n$  after  $n$  passes through the resonator is to stay limited, so  $\lambda$  has to either be unity or comprise an imaginary part.  $\lambda = 1$  does not really represent stability since any (physically always existing) deviation in  $g_i$  leads to limitless growth or decrease of  $\lambda^n$ . So

$$|(2g_1 g_2 - 1)^2 - 1| < 0$$

to make the square root imaginary, thus

$$(2g_1 g_2 - 1)^2 < 1$$

## Theory (32/54)

$$|2 g_1 g_2 - 1| < 1$$

$$-1 < 2 g_1 g_2 - 1 < 1$$

$$0 < 2 g_1 g_2 < 2$$

$$0 < g_1 g_2 < 1$$

is the stability criterion for a laser resonator. The eigenvalue is a periodic solution of the form

$$\lambda^2 = e^{\pm i n \phi} \text{ or } \lambda = e^{\pm i \phi} \text{ and}$$

$$Re(\lambda) = \cos \phi = 2 g_1 g_2 - 1$$

## Theory (33/54)

*Additional theory*

This way of exploring properties of an optical waveguide consisting of lenses, mirrors and free space along an optical axis can be simplified, if for each element of the optical waveguide a ray transfer matrix is specified. The behavior of several elements in series is described by the matrix product of the matrices of each element. Each matrix maps the angle  $\theta_i$  and distance  $x_i$  of the input ray of the optical element to the output ray's angle  $\theta_0$  to optical axis and distance  $x_0$  from optical axis.

For example the matrix  $\overline{\overline{L}}$  for a thin lens with focal length  $f$  is with positive  $f$  for converging lenses

$$\overline{\overline{L}} = \begin{pmatrix} 1 & 0 \\ -\frac{1}{f} & 1 \end{pmatrix}$$

## Theory (34/54)

and the matrix  $\overline{\overline{L}}$  for free beam propagation along the distance  $d$  is

$$\overline{\overline{S}} = \begin{pmatrix} 1 & d \\ 0 & 1 \end{pmatrix}$$

Since the behavior of a resonator with concave mirrors in distance  $d$  is similar to a set of converging lenses with the same focal length in the same distance, the above matrix  $\overline{\overline{M}}$  is

$$\overline{\overline{S}} = \overline{\overline{L}}_1 \cdot \overline{\overline{S}} \cdot \overline{\overline{L}}_2 \cdot \overline{\overline{S}}$$

to be read as " $L_1$  after  $S$  after  $L_2$  after  $S$ ".

## Theory (35/54)

The sequence of the matrices is of importance since the matrix product is not commutative as in physical reality it is of course of importance which lens comes first e.g. which end of the telescope you hold to your eye.

The behavior of the system is then described by the equation

$$\begin{pmatrix} x_f \\ \theta_f \end{pmatrix} = \overline{\overline{M}} \cdot \begin{pmatrix} x_i \\ \theta_i \end{pmatrix}$$

## Theory (36/54)

### Task 3

The actual electro-magnetic field distribution inside the laser cavity can not be fully determined by geometrical optics since the laser beam is diffraction limited. One more condition to be fulfilled for a stable resonator mode is that the mirror surfaces be planes of constant phase of the light waves for fundamental longitudinal modes or may only have some node lines on the mirror surface for non-fundamental transversal modes.

In a calculation this is done by introducing continuity criteria for the electric field at the mirror surface as boundary condition for the differential equations describing the electrical field. Also for the resonator finesse it has to be kept in mind that resonator quality is reduced due to diffraction on apertures as discharge capillary and mirror rims which lessen the light intensity in the cavity by coupling some light out of the resonator.

## Theory (37/54)

A solution for the field distribution fulfilling the requirements of both geometrical optics and diffraction in the cavity for a fundamental longitudinal mode is always provided by a Gaussian beam. So the actual beam properties are here compared to the theoretical properties of a Gaussian beam.

A Gaussian beam is characterized by the following properties:

- A Gaussian beam has rotational symmetry about its axis of propagation.
- An ideal lens or mirror always transforms one Gaussian beam into another.
- The transversal profile, that is the radial (in  $\rho$ -direction) intensity profile perpendicular to the optical axis, of a Gaussian beam propagating along the optical axis in  $z$ -direction is a Gaussian bell-shaped function, the normal distribution function. Thus has the beam no actual boundaries but is laterally extended to infinity. The beam width  $w$  is defined as the radius, where the intensity has decreased by  $1/e \approx 0.36788$ .

## Theory (38/54)

- Practically the exponential decay of intensity with growing distance to optical axis  $\rho$  provides that the rims of mirrors and lenses can be neglected in some or most cases.
- For the longitudinal profile along the optical axis in  $z$  direction can be said: A Gaussian beam has a beam waist at  $z = z_w$  with a minimal spot size  $w_0$ . In the following the origin of the  $z$ -axis  $z = 0$  is set to the position of the waist,  $z_w = 0$ . The beam width  $w(z)$  depends on  $z$  as

$$w(z) = w_0 \sqrt{1 + \left(\frac{z}{z_0}\right)^2} \quad (1)$$

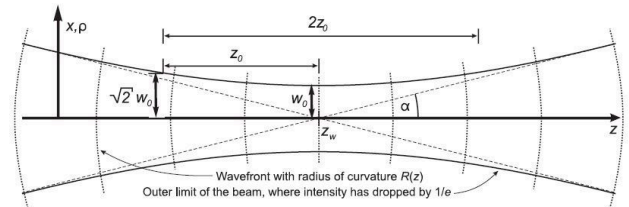

Diagram of a Gaussian beam waist,  $z$ -axis coincide with the optical axis

## Theory (39/54)

with the Rayleigh range or depth of focus

$$z_0 = \frac{\pi w_0^2}{\lambda} \quad (2)$$

At a distance from the waist equal to the Rayleigh range  $z_0$ , the width  $w$  of the beam is

$$w(\pm z_0) = w_0 \sqrt{2}.$$

The wave fronts in a Gaussian beam, that is the planes of constant phase, have a curvature

$$R(z) = z \left(1 + \left(\frac{z_0}{z}\right)^2\right) \quad (3)$$

## Theory (40/54)

Especially the wave front is flat in the centre of the beam waist, that is  $R(z_w) = \infty$  is indefinite. Seen from the beam waist, the curvature of the wave fronts is always concave, so if this formula is to be applied, the radius of curvature is defined (in contrast to Task 2) negative if concave is seen from right, that is from the positive end of the z-axis all along the optical rail.

Far away from the beam waist or Rayleigh range  $|z| \gg z_0$  the Gaussian beam has a constant divergence, which means the beam opens like a cone with opening angle  $2\alpha$ ,  $\alpha$  the angle between cone surface and optical axis

$$\alpha = \arctan\left(\frac{\omega(z)}{z}\right) \approx \frac{\omega(z)}{z} \quad (4a)$$

and with help of (1),  $|z| \gg z_0$  and (2)

## Theory (41/54)

$$\alpha = \arctan\left(\frac{\omega_0}{z_0}\right) \approx \frac{\omega_0}{z_0} = \frac{\lambda}{\pi \omega_0} \quad (4b)$$

The central phase on the optical axis shifts from inside the Rayleigh range to outside with the Gouy phase

$$\xi(z) = \arctan \frac{z}{z_0} \quad (5)$$

This contributes to a phase shift of  $\pi$  for  $|z| < z_0$  to  $|z| > z_0$ .

To assess the quality of laser beams, their actual properties are compared to the properties of a Gaussian beam as the best achievable beam quality. The quality of laser beams is often described by the beam parameter product (BPP). The BPP is the product of divergence angle  $\alpha$  and beam waist radius  $\omega_0$ ,  $BPP = \alpha \cdot \omega_0$ . The lower the BPP, the better the beam quality.



## Theory (42/54)

$$\alpha = \arctan\left(\frac{\omega_0}{z_0}\right) \approx \frac{\omega_0}{z_0} = \frac{\lambda}{\pi \omega_0} \quad (4b)$$

The central phase on the optical axis shifts from inside the Rayleigh range to outside with the Gouy phase

$$\xi(z) = \arctan \frac{z}{z_0} \quad (5)$$

This contributes to a phase shift of  $\pi$  for  $|z| < z_0$  to  $|z| > z_0$ .

To assess the quality of laser beams, their actual properties are compared to the properties of a Gaussian beam as the best achievable beam quality. The quality of laser beams is often described by the beam parameter product (BPP). The BPP is the product of divergence angle  $\alpha$  and beam waist radius  $\omega_0$ ,  $BPP = \alpha \cdot \omega_0$ . The lower the BPP, the better the beam quality.

## Theory (43/54)

It is minimal for a Gaussian beam with  $BPP = \lambda/\pi$ . The measured BPP divided by  $\lambda/\pi$  is according to ISO 11146 a measure for laser beam quality and called  $M^2$  factor with  $\alpha = M^2 \cdot \lambda/(\pi \cdot \omega_0)$

In a HeNe laser  $M^2$  factors near unity may be achieved and the beam is then called diffraction limited or Gaussian. Ideally a Gaussian beam establishes in the laser cavity such that the curvature of the wave fronts  $R(z)$  matches the mirror curvatures.

So from the knowledge of mirror spacing and curvature the position of beam waist  $z_w$ , beam waist radius  $\omega_0$  and, angle of divergence  $\alpha$  may be determined. Let's put the z-axis origin to the left mirror with curvature  $r_1$  and a second mirror with curvature  $r_2$  to  $z = d$ . As simplest case one mirror is flat with  $r_1 = \infty$  and so the beam waist is situated on the left mirror,  $z_w = 0$

## Theory (44/54)

So (3) becomes

$$R(d) = r_2 = d \left(1 + \frac{z_0^2}{d^2}\right) \rightarrow z_0^2 = d(r_2 - d)$$

with  $0 < d < r_2$  and with (2) solved for  $\omega_0$ :

$$\omega_0^4 = \left(\frac{\lambda}{\pi}\right)^2 \cdot d(r_2 - d) \quad \text{or} \quad \omega_0 = \sqrt{\frac{\lambda}{\pi} (\sqrt{d} (r_2 - d))} \quad (6)$$

The beam radius on the right mirror  $\omega(d)$  is then according to (1)

$$\omega(d) = \omega_0 \sqrt{1 + \frac{d}{r_2 - d}} = \sqrt{\frac{\lambda}{\pi} (\sqrt{d} (r_2 - d)) + \sqrt{\frac{d^3}{r_2 - d}}} \quad (7)$$

## Theory (45/54)

The angle of divergence  $\alpha$  is then according to (4)

$$\alpha = \sqrt{\frac{\lambda}{\pi} \frac{1}{\sqrt{d} (r_2 - d)}} \quad (8)$$

### *Additional theory*

The field distribution in a Gaussian beam is the solution of the Helmholtz equation in paraxial approximation – the time and phase dependent part of the Helmholtz equation already separated with the method of separation of variables:

$$\Delta_T A - i \cdot 2k \frac{\delta A}{\delta z} = 0$$

## Theory (46/54)

with the time and phase independent amplitude  $A(\vec{r})$  of the electric field and the transverse form of the Laplacian operator

$$\Delta_T = \nabla_T^2 = \frac{\delta^2}{\delta x^2} + \frac{\delta^2}{\delta y^2} = \frac{1}{\rho} \frac{\delta}{\delta \rho} \left( \rho \frac{\delta}{\delta \rho} \right) + \frac{1}{\rho^2} \frac{\delta^2}{\delta \Psi^2}$$

in cylinder coordinates  $\rho$  and  $\Psi$ . Paraxial approximation is as in Task 2:

$$\sin \theta \approx \theta \quad \text{or} \quad \left| \frac{\delta A}{\delta z} \right| \ll |kA| \quad \text{and} \quad \left| \frac{\delta^2 A}{\delta z^2} \right| \ll |k^2 A|$$

The solution for complex electric field amplitude  $E(\vec{r})$  at position vector  $\vec{r}$  including phase information but ignoring time dependency is then not dependent on  $\Psi$

## Theory (47/54)

$$E(\vec{r}) = A(\vec{r})e^{-ikz} = E(\rho, z) = E_0 \frac{\omega_0}{\omega(z)} e^{-\frac{\rho^2}{\omega^2(x)}} e^{-ik \frac{\rho^2}{2R(x)}} e^{-i\xi z} e^{-ikz}$$

and the intensity distribution, which is not phase-sensitive, is

$$I(\rho, z) = \frac{|E(\rho, z)|^2}{2\eta} = I_0 \left( \frac{\omega_0}{\omega(z)} \right)^2 e^{-\frac{2\rho^2}{\omega^2(x)}}$$

$\eta$  is the vacuum impedance or approximately 377 Ohm. To discuss the  $\rho$  - dependency of  $I(\rho, z)$  we choose an arbitrary but fixed  $z$  value  $z_f$ . For every  $z_f$ ,  $I(\rho, z)$  is a function with respect to  $\rho$  that describes the field intensity transversal to the direction of propagation.

## Theory (48/54)

Compared to the Gaussian normal distribution

$$f(t) = \frac{1}{\sigma \sqrt{2\pi}} e^{-\frac{2\rho^2}{2\omega^2(x)}}$$

it is  $\omega = \sqrt{2}\sigma$  which has to be kept in mind when calculating beam width  $\omega$  from a Gaussian scaled normal distribution fitted to the measurement data.

We use the phase plane curvaturaion to discuss  $z$  dependency of  $I(\rho, z)$

$$R(z) = (z - z_w) \frac{I(\rho=0, z)}{I_0}$$

## Theory (49/54)

If the beam waist is not at a mirror, that is both mirrors are curved, then

$$R(z) = (z - z_w) \left(1 + \frac{z_0^2}{(z - z_w)^2}\right)$$

Then the phase plane curvature  $R(z)$  is negative  $R(z) < 0$  for  $z < z_w$  that is left from the beam waist and positive  $R(z) > 0$  for  $z > z_w$  which is right from the beam waist. For consistency the curvature of the mirrors has to be defined to be negative if concave watched from right or positive  $z$ -axis. Let's put  $z = 0$  to the left mirror with curvature  $r_1$  and the second mirror with curvature  $r_2$  at  $z = d$ , then if wave front curvature is to match the mirror curvature:

$$R(z = 0) = r_1 = -z_w - \frac{z_0^2}{z_w} \quad (*)$$

## Theory (50/54)

$$R(z = d) = r_2 = d - z_w + \frac{z_0^2}{d - z_w} \quad (**)$$

$$(*) \quad z_w^2 + r_1 z_w + z_0^2 = 0$$

$$(**) \quad z_w^2 + (r_2 - 2d) z_w + d^2 - dr_2 + z_0^2 = 0$$

$$(*) - (**) \quad z_w = \frac{d(d-r_2)}{r_1 - r_2 + 2d} \quad (***)$$

From (\*) follows

$$(**) \quad z_0^2 = -z_w (r_1 + z_w) = -(z_w^2 + z_w \cdot r_1)$$

## Theory (51/54)

and since  $z_0$  has to be a real number, it is  $-r_1 < z_w < 0$  for  $r_1 > 0$  and  $0 < z_w < r_1$  for  $r_1 < 0$

With  $z_0 = \frac{\pi \omega_0^2}{\lambda}$  and (\*) is then

$$\omega_0^4 = -\left(\frac{\lambda}{\pi}\right)^2 \cdot z_w (r_1 + z_w) = -\left(\frac{\lambda^2}{\pi^2}\right) z_w^2 \left(\frac{r_1}{z_w} + 1\right)$$

$$(*) - (**): \quad w_0 = \sqrt{\frac{\lambda}{\pi} |z_w|} \sqrt{-\left(\frac{r_1}{z_w} + 1\right)} \quad (***)$$

where you may fill in (\*\*\*)

## Theory (52/54)

### Task 6

As a simple description of the diffraction grating the following holds: Constructive interference of the light diffracted at adjacent grating lines occurs when the optical path length difference  $\delta$  is multiples of a whole wavelength  $\lambda$ .

For many lines this leads to sharply defined angles in which the light of a single frequency is diffracted. The optical path length difference  $\delta$  for light emitted under the angle  $\alpha$  from two lines separated by distance  $l$  can be evaluated using trigonometry from the following sketch

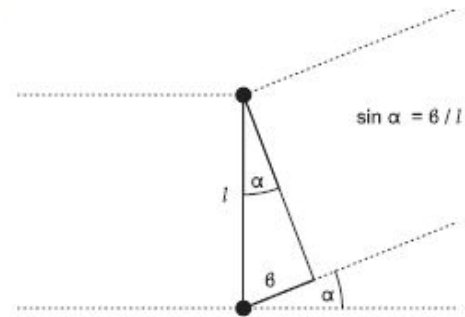

Sketch of optical path length

## Theory (53/54)

to be

$$\delta = l \cdot \sin \alpha$$

and with condition for constructive interference

$$\delta = n \cdot \lambda$$

for natural number  $n$  is the angle  $\alpha$

$$\alpha = \arcsin(n \cdot \lambda / l)$$

or

## Theory (54/54)

$$\lambda = (l/n) \cdot \sin \alpha = (l/n) \cdot \sin \arctan (y_{sn}/z_{gs})$$

since

$$\tan \alpha = y_{sn}/z_{gs} .$$

A more precise statement about the diffracted light of a grating might be:

If the grating has in direction  $x$  a transmissivity function  $f(x)$  and the transmissivity is independent on direction  $y$  perpendicular to  $x$  and the grating gets irradiated with parallel monochromatic light of wavelength  $\lambda$  in direction  $z$  perpendicular to  $x$  and  $y$ , the diffraction pattern in direction  $x$  is the Fourier transform of the transmission function  $f(x)$  scaled in size with the inverse of  $\lambda$ , that is the wavenumber.

## Equipment

Position	Material	Item No.	Quantity
1	Experiment set Helium-Neon Laser	08656-93	1
2	Photoelement	08734-00	1
3	Digital multimeter, 600V AC/DC, 10A AC/DC, 20 M $\Omega$ , 200 $\mu$ F, 20 kHz, $-20^{\circ}$ C... 760 $^{\circ}$ C	07122-00	1
4	Scale, l = 750 mm, on rod	02200-00	1
5	Diffraction grating, 600 lines/mm	08546-00	1
6	Plate holder	02062-00	1
7	Slide mount for optical bench expert	08286-00	1
8	Barrel base expert	02004-00	1
9	Vernier calliper stainless steel 0-160 mm, 1/20	03010-00	1
10	Sliding device, horizontal	08713-00	1
11	Connection box	06000-00	1
12	Resistor 10 Ohm 2%, 2W, G1	06056-10	1
13	Resistor 100 Ohm 2%, 1W, G1	06057-10	1
14	Resistor 1 kOhm, 1W, G1	39104-19	1
15	Resistor 10 kOhm, 1W, G1	39104-30	1
16	Resistor 100 kOhm, 1W, G1	39104-41	1
17	Connecting cord, 32 A, 750 mm, red	07362-01	1
18	Connecting cord, 32 A, 750 mm, blue	07362-04	1
19	Protection glasses HeNe-laser	08581-10	1
20	Cleaning set for laser, without cleaning liquid	08582-02	1
21	Acetone, chemical pure, 250 ml	30004-25	1



**PHYWE**  
excellence in science

## Setup and procedure

### Setup (1/2)

**PHYWE**  
excellence in science

Figure shows the fundamental setup for the experiments.

Fundamental set-up

## Procedure (1/43)

**PHYWE**  
excellence in science

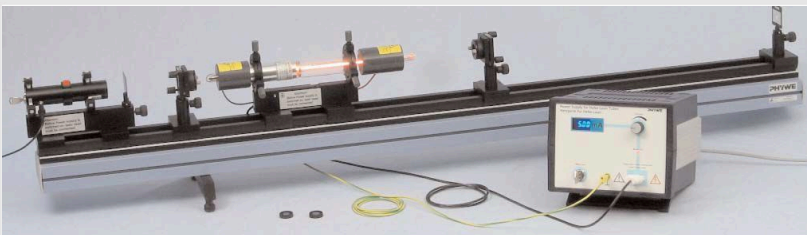
### Task 1

All fixing screws on the optical rail should always be tightened well so no components can unintentionally move, but without exerting exaggerated force!

A main objective of the present experiments is to gain a fine grasp of the handling of optical components and adjustment techniques which are necessary to successfully execute them. So the principles of adjustment and movement of components while operating the laser and of beam walking should be rehearsed to some extent.

## Procedure (2/43)

**PHYWE**  
excellence in science

### a. Adjusting the optical axis

- Place the optical bench on a firm surface and adjust its leveling screws such that the bench cannot wobble.
- Mount the adjustment laser to its holder and the left diaphragm in front of it, mount both at the left end of the rail.
- Mount the right diaphragm into a holder and mount it to the right end of the rail.
- Turn the Adjustment laser on.
- Adjust the adjustment laser position if necessary so that the beam passes the holes of both diaphragms and the interference pattern on the right diaphragm is as precisely centered as possible.

## Procedure (3/43)

**PHYWE**  
excellence in science

### b. Mounting the HeNe laser

- Mount the laser tube onto the rail remembering the order of tightening of the two screws that fix the laser tube holder to the rail. When removing or moving the laser tube holder use the same order of tightening the holding screws again when fixing the laser tube holder back on the rail.
- Left end of the tube should be about 300 mm away from the left diaphragm.
- Adjust the laser tube position such that the alignment beam passes through it without touching the capillary. Watch the reflections on the capillary. The visible light spot on the right diaphragm should not be distorted.
- The laser tube may slightly deflect the alignment beam. It is crucial, that the light passes completely through the tube and no distortion of the beam is visible, the deflection may be ignored.
- Remove the laser tube again not altering it's adjustment.

## Procedure (4/43)

**PHYWE**  
excellence in science

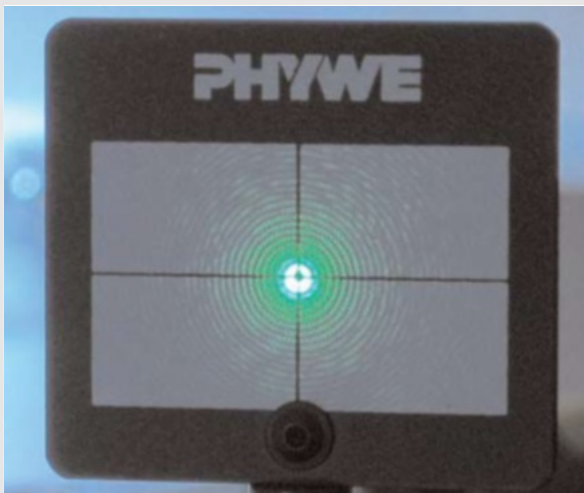

Good alignment of the adjustment beam

- Insert the concave high reflective (HR) flat/1000 mm mirror into an adjustable holder, the HR side facing left.
- Set the holder 900 mm away from the left diaphragm onto the rail and adjust the reflection position precisely centre of the left diaphragm.
- The reflexes of front and back side of the mirror can be distinguished: When moving the mirror along the rail the useful front reflex shows focusing while the uninteresting back reflex does not.
- Insert HR flat/flat mirror into an adjustable holder, the HR side facing right.

## Procedure (5/43)

**PHYWE**  
excellence in science



Bad laser tube alignment

- Place the holder 200 mm away from the left diaphragm and adjust the reflected beam position precisely centre of the left diaphragm.
- Insert the laser tube at its former position, turn on its power supply and set the tube current to 6.5 mA.
- Wobble the adjusting screws on the right mirror – one fast and one slow scanning the x-y-range of the reflected alignment beam watching the reflection of the alignment beam on the left diaphragm. The reflected alignment beam should be seen passing back through the tube and the left mirror on the left diaphragm.

## Procedure (6/43)

**PHYWE**  
excellence in science

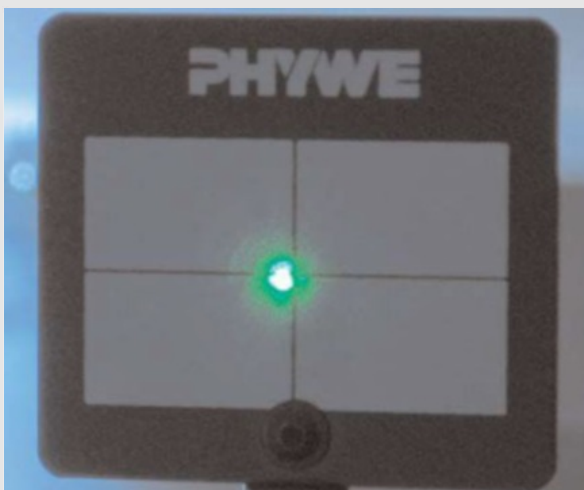

Good laser tube alignment

- When the alignment beam is centered on the left diaphragm, the laser should ignite at some point. If not, continue the x-y-scanning with some patience.
- After seeing the laser ignite, optimize the laser output power by successively adjusting every element of the laser system: tube position, left mirror and right mirror.
- Iterate the optimizing process until no more intensity improvement can be achieved.
- The beam diameter on the left diaphragm is clearly smaller than on the right one.

## Procedure (7/43)

**PHYWE**  
excellence in science



Beam centered on the right diaphragm with ghost beam visible left of it.

### c. Beam walk the laser to the optical axis

- Turn the adjustment screws on the left mirror and watch the behavior of the laser light spot on the right diaphragm.
- Let the laser spot move towards the centre of the diaphragm as far as possible without extinguishing the laser.
- Read just all components but the left mirror to optimize the laser intensity and iterate this readjustment until optimum is reached.

## Procedure (8/43)

**PHYWE**  
excellence in science

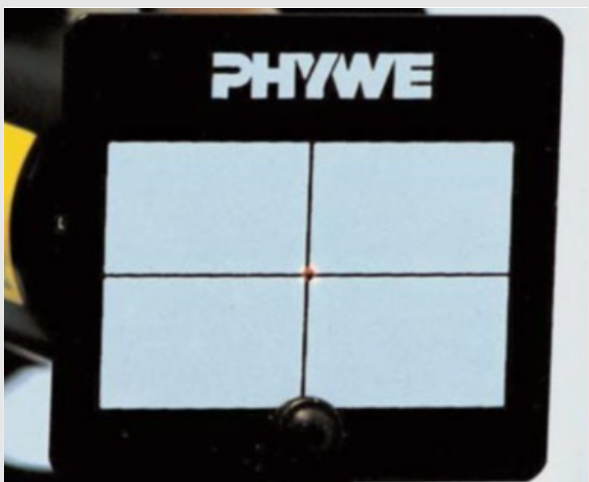

After beam walking the beam passes almost completely the hole in the left diaphragm.

- Turn the left mirror again in the desired direction without extinguishing the laser and go through the optimizing process once more.
- Repeat the procedure until the beam is precisely centered on the right diaphragm.
- Continue beam walking with the spot on the left diaphragm turning the right mirror until laser beam and optical axis are well aligned.
- Especially alter the laser tube alignment in the desired direction.

## Procedure (9/43)

**PHYWE**  
excellence in science

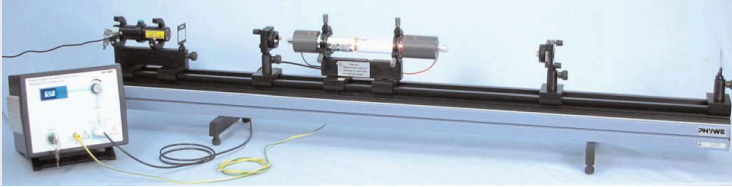

Experimental set-up

Good alignment of the laser parallel to the optical bench is crucial because components have to be moved along the rail to a good extent in the following experiments. Without proper alignment the readjusting after each step of movement becomes painful.

## Procedure (10/43)

**PHYWE**  
excellence in science

### Task 2

In this task the stability of an optical resonator will be investigated. Basically we are looking if the laser ignites or not at a special resonator geometry. The resonator geometry is specified by a set of values for the resonator parameters like distance between and curvatures of the mirrors. We identify an optical resonator with a certain geometry as stable if the laser ignites. Thus we determine the resonator stability by the stability of the laser process.

But two questions arise:

1. How is the resonator geometry related with the ignition of the laser?
2. What means resonator stability in geometrical terms?

## Procedure (11/43)

**PHYWE**  
excellence in science

The crucial point in the laser process is that photons once created by stimulated emission will produce further photons in subsequent processes of stimulated emission. But the laser can only ignite if the efficiency of this feedback is high enough.

Therefore most of the (approximately all) light produced in the laser process should stay in the active laser medium inside of the resonator to keep the laser process stable. Thus, roughly speaking, an optical resonator is said to be stable if light propagating inside of the resonator stays inside of the resonator.

We can be more precise using the concept of light paths constructed according to the laws of geometrical optic. In this terms a resonator is stable if the whole light path is inside the resonator.

In the theory part all used quantities will be defined precise and expressed in mathematical terms. An analytical stability criterion incorporating the resonator parameters will be explained and derived.

## Procedure (12/43)

**PHYWE**  
excellence in science



Laser moved to the left end of the optical rail

In this task **left** and **right** is defined according to the perspective of the figure.

Note: After each change in the set-up, the laser output is to be optimised again!  
After the set-up and alignment process described in Task 1, the laser is equipped with a high reflective (HR) flat/flat mirror on the left side and a concave HR flat/1000 mm mirror on the right side with a mirror spacing about 700 mm. This is a hemispherical resonator configuration.

## Procedure (13/43)

### a. Move the laser to the left end of the optical bench:

- Remove the alignment laser and the left diaphragm from the optical bench.
- Move the laser tube near to the flat/flat mirror on the left and optimize the laser power by aligning all components again.
- Move the left mirror further to the left – as far as possible such that the laser ignites again after tightening the mirror holder's fastening screw to the optical bench and optimize the laser power once more.
- Move the laser tube towards the left mirror and repeat output optimization.
- Move the right mirror towards the laser tube, repeat optimization.

## Procedure (14/43)

- Repeat these steps until the left mirror is at the left end of the optical bench and the laser tube right in front of it.
- Align the laser beam with the optical axis by beam walking centering the light spot on the right diaphragm.

### b. Determine the maximum mirror spacing in which the laser works for this mirror combination:

- Move the right mirror in steps as far as possible to the right so that the laser can still ignite – always optimizing laser intensity after each step.
- Watch light spot size on both mirrors and think about the implications for the necessary laser tube position since the capillary should not filter nor reflect laser intensity.
- At the critical distance the steps may need to be as small as some millimeters.



## Procedure (15/43)

**PHYWE**  
excellence in science

c. Alter the mirror combination to a hemispheric resonator with a different radius of curvature

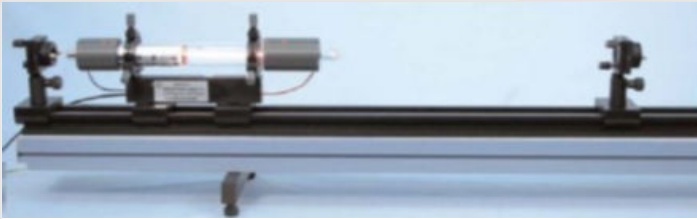

Set up with right mirror holder turned around

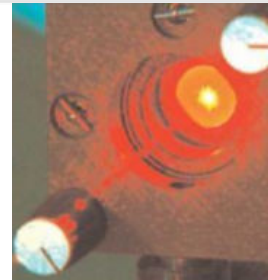

Mirror holder

## Procedure (16/43)

**PHYWE**  
excellence in science

- Lower the mirror distance to 850 mm while laser operates.
- Exchange the **right** mirror with the concave **HR flat /1400 mm** mirror: Turn the mirror holder around so that the cavity length is extended and mount the mirror with the high reflective side facing to the inner of the mirror holder and facing left. The mirror surface position is now 45 mm from the left and 5 mm from the right corner of the mirror holder.
- Start the laser up again scanning the x-y-range with the right mirror, spinning one screw fast and the other slow.
- If the room where you work is darkened, the reflection of the tube's light coming from the mirror seen on the end of the tube housing can be used to determine the correct mirror angle provided the laser is well aligned with the rail.

## Procedure (17/43)

**PHYWE**  
excellence in science

- If the laser tube position is not very far left and so the reflected light spot is not in focus and invisible, then the left mirror may be removed and replaced by the alignment laser to preadjust the right mirror. Then replace the alignment laser again with the left mirror without altering the left mirror's alignment.

If the laser tube position is not very far left and so the reflected light spot is not in focus and invisible, then the left mirror may be removed and replaced by the alignment laser to preadjust the right mirror. Then replace the alignment laser again with the left mirror without altering the left mirror's alignment.

- Scan the right mirror x-y-range to start up the laser.
- Determine the maximum mirror spacing in the same manner for this mirror combination.
- Remove the holder with the right diaphragm when necessary.

## Procedure (18/43)

**PHYWE**  
excellence in science

### **d. Alter the mirror combination to a confocal/concentric set up:**

- Lower the mirror distance to 600 mm keeping the laser operating.
- Move the laser tube near the right mirror.
- Exchange the left HR flat/flat mirror with the concave HR flat/1000 mm mirror, the holder position such that the holder protrudes a centimeter from the rail to the left.
- Reignite the laser now scanning with the left mirror.
- Check on the alignment of the optical axis with the rail with help of the right diaphragm, correct by beam walking if necessary.

## Procedure (19/43)

**PHYWE**  
excellence in science

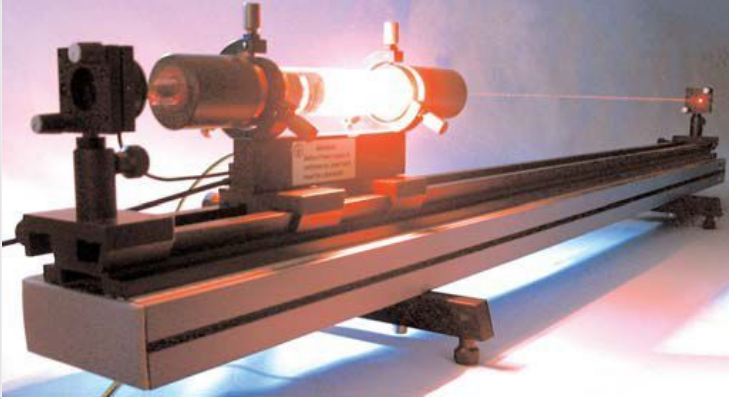

Laser working at full length of optical rail.

- Watch the beam diameter on both mirrors, keep the laser tube near the mirror where the diameter is small.
- Start the laser and rise the mirror distance again until the laser gets unstable, keeping the laser tube in front of the mirror with the small beam diameter.
- Now try to reach a second area of stability where the beam diameter is small on the left mirror: Bring the laser tube as far as possible near the left mirror while laser operating.

## Procedure (20/43)

**PHYWE**  
excellence in science

Put the right mirror holder to the right end of the optical rail, the holder protruding one centimeter from the rail's end to the right. Mirror distance  $d$  is then 1465 mm.

Watch the tube light's reflection from the right mirror to adjust the right mirror orientation: The reflection is to match the light beam coming out of the tube, check e.g. with white sheet of paper.

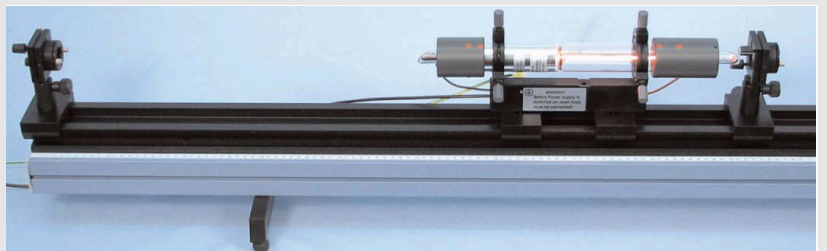

Laser tube near right mirror.

## Procedure (21/43)

**PHYWE**  
excellence in science

- With a little scanning you should be able to ignite the laser in this position.
- If not successful check beam alignment with low cavity length and right diaphragm – correct by beam walking with left mirror and tube alignment.
- Try to lower the mirror distance as far as possible.

## Procedure (22/43)

**PHYWE**  
excellence in science

### Task 3

Note: In this task left and right is defined according to the perspective of figure.

Now the geometrical properties of the beam will be investigated. The dependence on the geometrical properties of the resonator will be analysed.

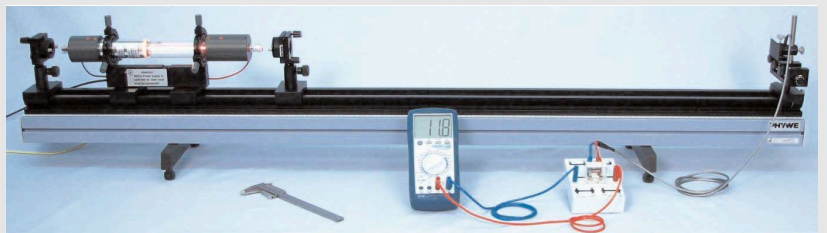

Laser tube near right mirror.

## Procedure (23/43)

**PHYWE**  
excellence in science

Practically we will measure the beam diameter in front of the left and the right resonator mirror (thus inside of the resonator) and at the end of the optical rail. This will be done for different resonator lengths and for different mirror curvatations.

The experimental procedure of the diameter measurements inside of the resonator is similar to the procedure of Task 2: With help of the outside jaws of a vernier caliper a slit of specific width is preset. These slit will be moved perpendicular to the beam axis in front of the left (right) mirror. This will be done for different slit widths.

We identify the beam diameter in front of the left (right) mirror as the smallest slit widths at which the laser ignite. We can do so for the same reason as in Task 2: Only if the (approximately) whole light of the laser beam can pass the slit the efficiency of the feedback in the laser process is high enough to ignite the laser.

## Procedure (24/43)

**PHYWE**  
excellence in science

The diameter of the beam at the end of the optical rail (i.e. outside of the resonator) will be determined in a different way: With help of a photoelement the photo current induced by the laser beam will be measured. The dependency of the current from the distance of the photo element from the beam axis reflects the transversal beam profile. The beam profile can be fitted with a Gaussian bell-shaped curve and the beam will be determined by the width of the bell shaped curve.

- Equip the laser with the HR flat/flat mirror on the left side and the HR flat/1000 mm mirror on the right side.
- Set the tube current to 5 mA and bring the laser into operation.
- Remove the alignment laser and the slide mount with the right diaphragm.
- Move the laser under operation to the outmost left end of the optical rail.

## Procedure (25/43)

**PHYWE**  
excellence in science

- Set the mirror distance  $d$  to 450 mm, optimize laser output.
- The laser tube is to be near the left mirror but with enough space between mirror and tube to measure the beam diameter there with the caliper.
- Mount the horizontal slide device to the slide mount without column on the outmost right end of the optical rail.
- Mount the silicon photo element onto the slide device and connect it to a  $10\text{ k}\Omega$  resistor on the the connection box.

## Procedure (26/43)

**PHYWE**  
excellence in science

- Connect the digital multimeter to measure the voltage drop on the resistor with the current from the photo element passing the resistor (see circuit diagram).
- Use for example black adhesive tape or black adhesive labels to shorten the slit of the faceplate for the photo element to a centered square ( $0.3\text{ mm} \times 0.3\text{ mm}$ ) and mount the faceplate onto the photo element.

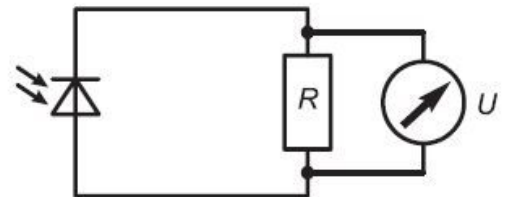

Circuit diagramm

## Procedure (27/43)

**PHYWE**  
excellence in science

- One turn of the adjusting knob of the slide device is half a millimeter of lateral movement; the spindle counts up to 15 turns, that is 7.5 mm, before starting at zero again.
- Mind the lost motion, move the slide device always only from one side to the desired position while measuring.
- Check on the laser mode with a white piece of paper in front of the photo element.

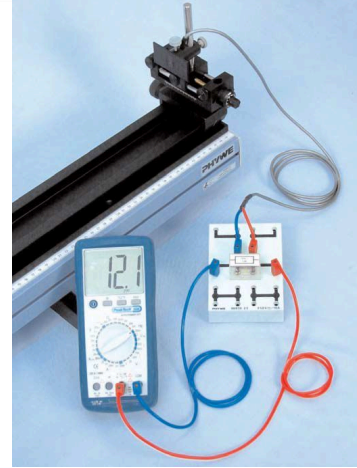

Sliding device with photo element.

## Procedure (28/43)

**PHYWE**  
excellence in science

- The laser light spot is to appear round and symmetric corresponding to the  $T_{00}$  - mode, that is the fundamental transversal mode, belonging to a Gaussian beam. If the laser oscillates in a  $T_{01}$  - mode, that is the first non-fundamental transversal mode, or another non-fundamental mode if brightest, the optics need cleaning.
- Use the digital multimeter to determine the actual resistance value. Be sure the input resistance of the multimeter in use is at least ten times higher than the used resistors.
- Register the photo element current (not voltage!) which is proportional to the light intensity in a profile perpendicular to the optical axis and through the centre of the laser beam.
- Calculate the current by Ohm's law from the voltage on the resistor.
- If the voltage exceeds 60 mV, use a lower resistance value.

## Procedure (29/43)

**PHYWE**  
excellence in science

- Record about one measuring point per half millimeter, that is one turn of the knob.
- Measure the beam diameter in front of the left mirror  $w_0$  and in front of the right mirror  $w(d)$  with the caliper: Set the caliper to a specific width and check if the laser flashes if the caliper slit moves perpendicular to the optical axis through the resonator and the slit matches somewhere the optical axis – use the thin part of the caliper slit, try with different angles between caliper scale and optical axis; note the lowest caliper spacing for which a laser flash can be seen as beam width.

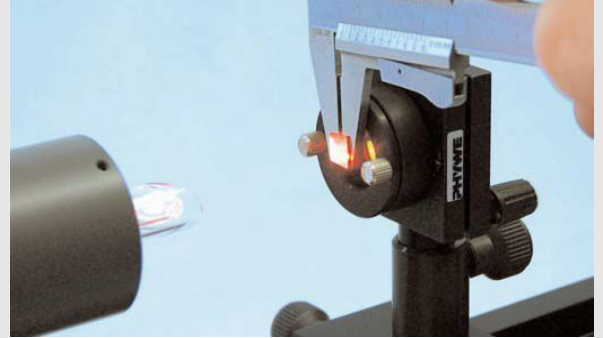

Beam width measurement with a caliper.

## Procedure (30/43)

**PHYWE**  
excellence in science

- Set the mirror distance  $d$  to different values less than 1000 mm where the laser is still stable and repeat the measurement.

### Notes

- A ghost beam may be seen as a result of the wedge form of the mirror: Multiple reflections occur inside the mirror glass because of imperfect antireflection coating of the mirror's back side. These reflections interfere with the main laser beam. To reduce the disturbance caused by them, the mirror is made in a wedge shape, that is front and back side are not parallel, so the reflections differ in direction from the main beam. The intensity distribution is distorted by the ghost beam. This distortion is to be neglected.
- In the ideal case of infinite resistance the photo element voltage is independent on the light intensity and equal to the band gap of the element. It decreases with lower resistance to greater extent the less incident light is available.



## Procedure (31/43)

**PHYWE**  
excellence in science

- For accurate proportionality of photoelement current to incident photon rate a reverse bias could be applied to the photo element. Then an only temperature dependent dark current from intrinsic conductivity of the element may be present and has to be subtracted from the readings. Such an accuracy is not needed in this experiment.
- The laser power can be calculated with the sensitivity of the photo element of 0.48 A/W.

## Procedure (32/43)

**PHYWE**  
excellence in science

### Task 4

Note: In this task left and right is defined according to the perspective of fundamental setup.

- Set the laser up as in Task 1, that is with HR flat/flat as left mirror and HR flat/1000 mm as right mirror.
- Set the tube current to 5.5 mA.

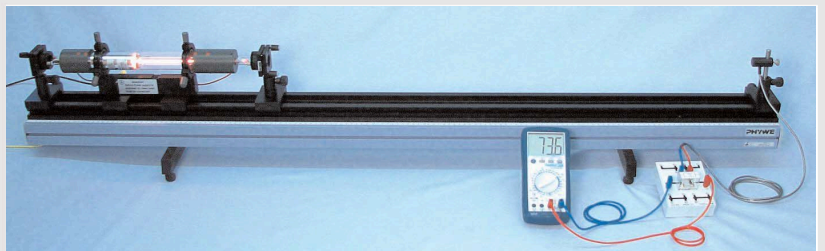

Set up for laser power measurement with different resonator geometries

## Procedure (33/43)

**PHYWE**  
excellence in science

- Move the laser set-up to the left end of the optical bench removing the adjustment laser and adjust laser axis to optical bench axis by beam walking.
- Move the right mirror to 420 mm distance dd to the left mirror, maximize laser output.
- Remove the right diaphragm from its slide mount and insert the silicon photo element without the blind there.
- Use the digital multimeter to determine the actual resistance value of a 1 k $\Omega$  resistor.
- Be sure the input resistance of the multimeter in use is at least ten times higher than the used resistor value.
- Connect the photo element to this 1 k $\Omega$  resistor on the connection box and align it such that it receives all the laser output.

## Procedure (34/43)

**PHYWE**  
excellence in science

- Measure the voltage on the resistor.
- If the voltage exceeds 60 mV, use a lower resistance value which you check with the digital multimeter.
- Connect the digital multimeter to measure the voltage drop on the resistor with the current from the photo element passing the resistor.
- Calculate the current by Ohm's law from the voltage on the resistor.

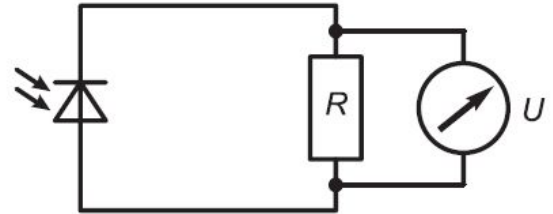

Photo element set-up

## Procedure (35/43)

**PHYWE**  
excellence in science

- Register the maximum achievable photo element current for different mirror spacings with the laser tube in front of the left mirror and note the visible mode shape.
- If the mode shape is not round, the mirrors and brewster windows need cleaning.
- Always note down the current from background light with no laser beam, the beam interrupted with a piece of paper between left mirror and left end of the laser tube, the tube light and maybe other stray light from the room still illuminating the photo diode; darken the room if excessive background is present.



Circuit diagramm

## Procedure (36/43)

**PHYWE**  
excellence in science

- With a fixed mirror distance register the maximum laser output for different laser tube positions inside the cavity, for example for  $d = 850$  mm and  $d = 700$  mm. You may use a specific point of the tube holder as reference for the position.
- Exchange the right mirror with the OC flat/1400 mm mirror and repeat the measurements, tube position variation only for  $d = 1050$  mm.
- Exchange the right mirror with the HR flat/1400 mm mirror and repeat the measurements, tube position variation only for  $d = 1050$  mm.
- The sensitivity of the photo element is assumed to be  $0.48 \text{ A / W}$  to calculate the laser power.

## Procedure (37/43)

**PHYWE**  
excellence in science

### Task 5

- Set the laser up as in Task 1, that is with HR flat/flat as left mirror but exchange the right mirror with the HR flat/1400 mm.
- Set the mirror distance to  $d = 450$  mm, optimize the laser output after each step of modification of the setup.

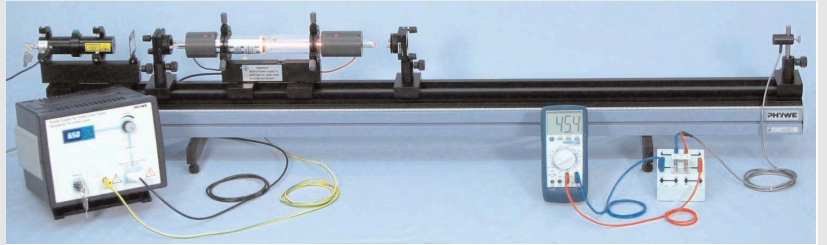

Experimental set-up

## Procedure (38/43)

**PHYWE**  
excellence in science

- Exchange the right diaphragm on the slide mount with the silicon photo element without the blind.
- Use the digital multimeter to determine the actual resistance value of the used resistors.
- Connect the photo element to a 1 k $\Omega$  resistor on the connection box and align it such that it receives all the laser output.
- Be sure the input resistance of the multimeter in use is at least ten times higher than the used resistor value.
- Connect the digital multimeter to measure the voltage drop on the resistor with the current from the photo element passing the resistor.

## Procedure (39/43)

**PHYWE**  
excellence in science

- Vary the laser tube current at the laser control unit measuring the voltage on the resistor for current settings from lowest possible up to 10 mA.
- Observe the uncoherent light intensity changes from the gas discharge by eye.
- Measure the voltage from the background light from the gas discharge and the room light when interrupting the laser beam left of the laser tube with a piece of paper and subtract it from the measured voltage with laser on for each current value.



Photo element connection

## Procedure (40/43)

**PHYWE**  
excellence in science

- Exchange the **right** mirror with the **OC flat/1400 mm** mirror, optimize laser output.
- Insert the 100  $\Omega$  resistor instead of the 1 k $\Omega$  resistor.
- Repeat the measurement.
- You may also try a high output configuration (left: HR flat/1000 mm, right: OC flat/1400 mm, d= 420 mm) and a nearly unstable configuration (left: HR flat/flat, right: HR flat/1000 mm, d= 950 mm).
- Do not expose the laser tube to currents exceeding 6.5 mA for extended time, turn the current down to 6.5 mA again at once after the measurement points are recorded.
- Keep in mind that the tube temperature rises with rising current leading to uncomparable results when turning the current down again until the tube cooled off. The laser power is temperature-dependent since the doppler linewidth and gas pressure are temperature-dependent.

## Procedure (41/43)

**PHYWE**  
excellence in science

- Calculate the current by Ohm's law from the voltage on the resistor.
- To calculate the laser power the sensitivity of the photo element is assumed to be 0.48 A / W.

Notes:

- You also may analyze the time-dependence of the laser output power with a LF-amplifier and a loudspeaker (Phywe Nr. 13625.93 and 13765.00) or with an oscilloscope (Phywe-Nr. 11459.95).
- For laser output power measurement in the mW range the photo element current may be directly measured with the digital multimeter 07123.00 in the  $\mu\text{A}$  setting without connection box and resistors.

## Procedure (42/43)

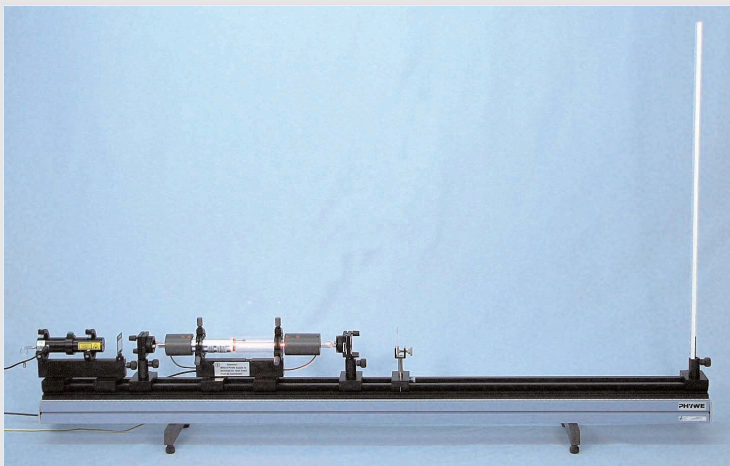
**PHYWE**  
excellence in science

Set-up for the wavelength measurement with optical grating.

### Task 6

Note: In this task left and right is defined according to the perspective of the figure.

- Set the laser up as in Task 1.
- Move laser tube and the cavity mirrors near the alignment laser.
- Observe the light emanating from the gas discharge through the grating by eye.

## Procedure (43/43)

**PHYWE**  
excellence in science

- Put the plate holder into the sliding mount without column right outside the laser cavity.
- Insert the diffraction grating with 600 lines per millimeter into the plate holder, grating lines horizontal so the diffraction is vertical.
- Insert the scale on rod into the sliding device where the right diaphragm was.
- Measure the distance between grating and scale  $z_{gs}$  with help of the scale on the optical bench and the caliper.
- Measure the distance between the undiffracted laser light spot and the first order diffracted spots  $y_{s1}$  on the vertical scale for the green and red laser light.
- For elimination of statistical errors measure at different distances between grating and vertical scale.

## Evaluation (1/21)

**PHYWE**  
excellence in science

### Task 2

Typical measurement results may be:

Maximal mirror spacing  $d_{max}$  for mirror combination 1):  $d_{max} = 967 \text{ mm}$

Maximal mirror spacing  $d_{max}$  for mirror combination 2):  $d_{max} = 1398 \text{ mm}$

Maximal mirror spacing  $d_{max,1}$  for mirror combination 3) and the first area of stability:  $d_{max,1} = 1052 \text{ mm}$

Minimal mirror spacing  $d_{max,2}$  for mirror combination 3) and the second area of stability:  $d_{max,2} = 1457 \text{ mm}$

## Evaluation (2/21)

**PHYWE**  
excellence in science

The deviations from theoretical values depend on

- a) damping by dirt and imperfections on the optics in case of impossible lasing though inside stability range
- b) presence of rays not in the plane of the optical axis as in doughnut-shaped or other transversal modes in case of lasing though outside stability range.

## Evaluation (3/21)

**PHYWE**  
excellence in science

### Task 3

Figure shows a plot for  $\omega_0$  and  $\omega_d$  for  $\lambda = 633 \cdot 10^{-9} \text{ m}$  and  $r_2 = 1000 \text{ mm}$ .

There is a maximal beam waist radius  $\omega_0$  of 0.317 mm for  $d = r_2/2 = 500 \text{ mm}$ .

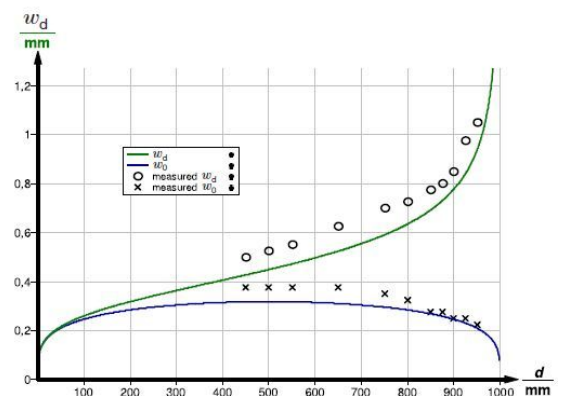

Calculated beam radius on the right mirror  $\omega_d$  and beam waist radius  $\omega_0$  in dependence on mirror spacing  $d$ .



## Evaluation (4/21)

Figure shows the intensity distribution of the laser beam measured at the end of the optical rail in dependence of distance to the optical axis 1400 mm away from the beam waist on the flat (left) mirror.

Fitting a gaussian scaled normal distribution to each series of measurement data yields an estimation of the standard deviation  $\sigma$  and thus the beam radius for each set of data.

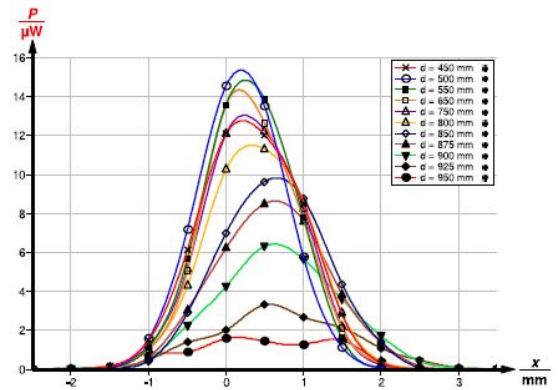

Laser light intensity measured perpendicular to the optical axis

## Evaluation (5/21)

Figure shows a plot for  $\lambda = 633 \cdot 10^{-9} m$  and  $r_2 = 1000 mm$ .

There is a minimal theoretical angle of divergence  $\alpha$  of 0.00063 rad or 0.036° or 2 arc minutes for  $d = r_2/2 = 500mm$ .

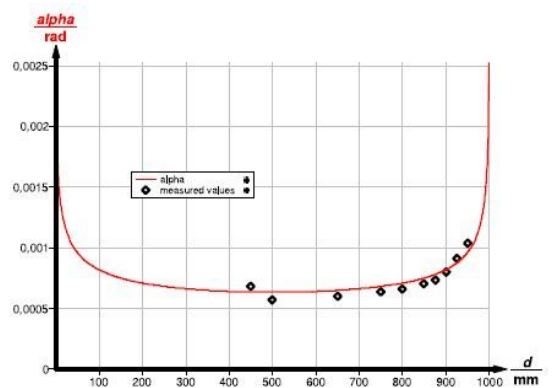

Calculated divergence angle  $\alpha$  according to (8) in dependence on mirror spacing  $d$

## Evaluation (6/21)

**PHYWE**  
excellence in science

It can be seen here that the beam properties are somewhat in the range of a Gaussian beam. One measurement error here is a principal error connected with intra-cavity beam width measurement with a caliper.

This overestimates the beam width since the laser does not ignite if only some percent of the power are filtered per resonator round trip of the light. So the measured value does not exactly match the radial 1/e intensity drop defined as beam radius.

Furthermore the total laser gain decreases with decreasing resonator stability with increasing mirror spacing  $d$ . So for a nearly unstable laser only a smaller portion of the beam diameter may be cut by the caliper to still ignite the laser.

## Evaluation (7/21)

**PHYWE**  
excellence in science

Figure visualizes the behavior of beam waist position  $z_w$  and beam waist radius  $w_0$  for the mirror combination used in Task 2,  $r_1 = -1000\text{mm}$  and  $r_2 = 1400\text{mm}$ . For  $d < 1000\text{mm}$  the beam waist stays inside the cavity in front of the right mirror and moves to the right with growing  $d$  and for  $1400\text{mm} < d < 2400\text{mm}$  the beam waist is near the left mirror. The beam waist radius is only defined for the stability regions  $0\text{mm} < d < 1000\text{mm}$  and for  $1400\text{mm} < d < 2400\text{mm}$ . The angle of divergence is not shown but is proportional to the inverse beam waist radius.

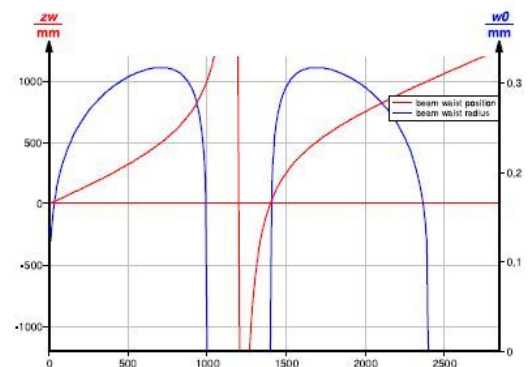

Calculated beam waist position  $z_w$  and beam waist radius  $z_0$  for  $r_1 = -1000\text{mm}$  and  $r_2 = 1400\text{mm}$  with distance  $d$  between the mirrors from 0 to 2800 mm.

## Evaluation (8/21)

**PHYWE**  
excellence in science

### Task 4

Figure shows output power in dependence on mirror spacing  $d$  with the laser tube fixed in front of the flat mirror. The x-axis corresponds to the mirror spacing  $d$  in mm.

In the figure, the left scale is for the measurement with outcoupling (OC) mirror and the right for the output through high reflective (HR) mirrors. It can be seen that the laser output is about 25 times higher with an OC mirror but the output dependence on mirror spacing is mainly the same.

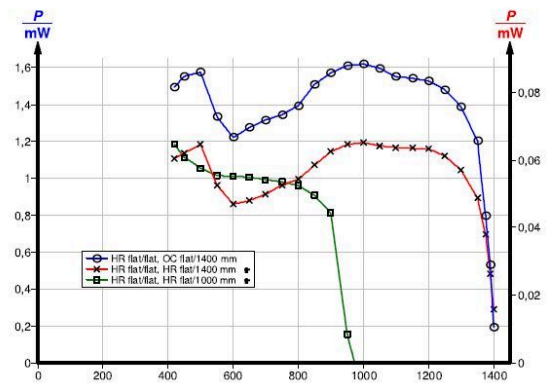

Output power in dependence on mirror spacing  $d$  with the laser tube fixed in front of

## Evaluation (9/21)

**PHYWE**  
excellence in science

Per unit time the gas discharge supplies an active amplifying gas volume by "pumping" with roughly the same extractable lasing energy per volume of discharge if the current density is uniform throughout the volume. Still the amplification may depend to some extent on radial distance from the capillary axis both due to radial temperature and density variation of the discharge gas and the deexcitation effect of the capillary wall which is a bottleneck to the population inversion.

There are both frequency and geometric effects:

- The laser output power is determined by the fraction of the active volume where oscillating modes have high light intensity: Only where a mode has high intensity, it can effectively converse the energy supplied by the active volume. The output power is the higher the better the active volume is filled with zones of high intensity by modes which may oscillate. The more possible modes, the better the volume fitting.

## Evaluation (10/21)

- The laser output power through the mirrors is also determined by diffraction losses: Each mode has diffraction losses on the laser capillary and the cavity mirrors which all work as mode blinds. If the actually oscillating modes have high diffraction losses they give off laser intensity (and power) to the sides along the laser cavity but not through the mirrors and these losses lessen the intra cavity intensity and thus the effectivity of energy extraction from the active volume.

For frequency effects:

- Per unit time the gas discharge uniformly distributes extractable lasing energy among gas atoms with different amount of speed in direction of the capillary axis and thus different resonance frequencies. Since longitudinal modes (to the same transversal mode number) differ in frequency, the higher the number of longitudinal modes the higher is the possible output power because of better filling of the frequency space.

## Evaluation (11/21)

With the cavity with a flat mirror on one side and the 1400 mm mirror on the other for small mirror distances both fundamental longitudinal modes and modes with non-zero transversal mode number and also doughnut-shaped modes do oscillate. The active volume is optimally filled, the diffraction losses low and the output power is high. At a mirror distance of 600 mm the capillary filters all non-fundamental transversal modes, only some transversal modes may oscillate and the output power has a minimum. With rising mirror distance the number of longitudinal modes rises and thus the output power.

For mirror distances over 1000 mm the active volume is no longer optimally filled since the mode diameter contracts on the flat mirror and for distances over 1200 mm the diffraction losses on the curved mirror, where the diameter expands, dominate and the laser power diminishes until the cavity becomes totally unstable at 1400 mm. With the cavity with a flat mirror on one side and the 1000 mm mirror on the other modes with non-zero transversal mode number are filtered already at the minimal mirror distance, the tube length. The rising of possible longitudinal mode numbers compensates for the diminishing useful fraction of the active volume with rising mirror distance until the distance exceeds 800 mm and the diffraction losses on the curved mirror dominate.

## Evaluation (12/21)

Figure shows the laser output power dependence on tube position for a cavity with a flat mirror on one side and the 1000 mm concave mirror on the other. The upper curve applies for a mirror distance of 700 mm and the lower curve for a mirror distance of 850 mm. As tube position an arbitrary but fixed point on the tube holder was selected.

The opening angle of the laser beam is greater for the greater mirror distance of 850 mm so the diffraction losses on the capillary opening that shows to the curved mirror, where the beam diameter is wider, are greater and the laser power diminishes faster when the tube is moved towards the curved mirror.

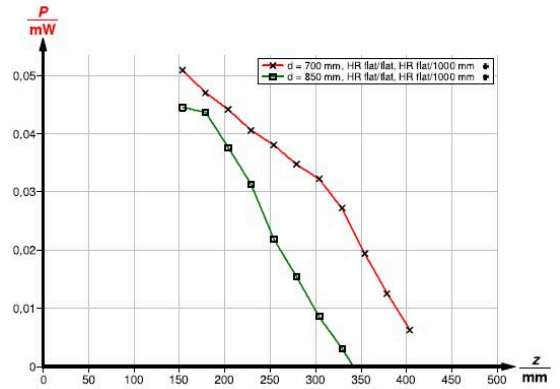

Laser output power in dependence on laser tube position for different mirror distances

## Evaluation (13/21)

In figure the left scale applies to the output through the OC mirror and the right to the output through a HR mirror of same curvature which was set as exchange for the OC mirror.

The cavity consisted of a HR flat mirror on one and a 1400 mm concave mirror on the other side. The output diminishes as the tube is moved towards the end of the cavity where the beam diameter is increasing because of the greater losses of a thicker beam on the capillary.

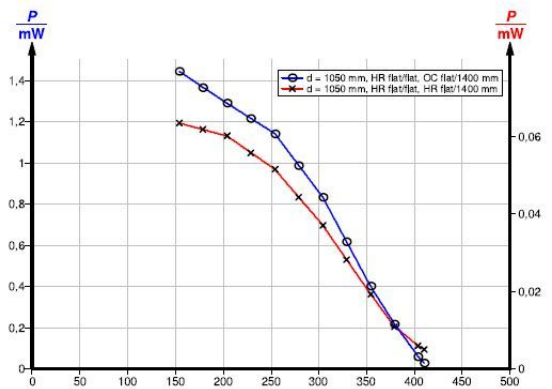

Laser output power in dependence on laser tube position The x-axis corresponds to the laser tube position z in mm.

## Evaluation (14/21)

Because of less outcoupling losses through the mirrors, the HR configuration can tolerate greater losses on the capillary and the lower curve is less steep at the end.

The bending of the curve is due to the fact that the tube is still in the Rayleigh range and the beam diameter does not increase linearly. Also the intensity fraction cut by a circular opening of a Gaussian beam is not linear with diameter.

## Evaluation (15/21)

### Task 5

Figure shows how the laser output power varies with the discharge current for a cavity configuration where optimal output can be extracted from the laser and a configuration that is almost unstable. In the first configuration with the OC mirrors the laser power is about 500 times higher compared to the latter almost unstable configuration. The left scale applies to the OC and the right scale to the HR configuration. In the HR configuration curve an example of curve distortion due to temperature variation is shown.

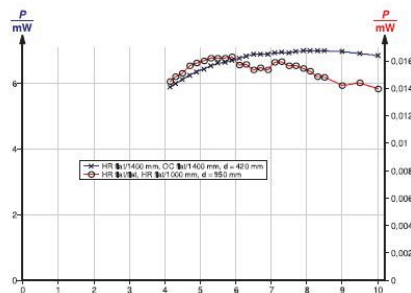

Laser output power in dependence on discharge current in high output and in nearly

## Evaluation (16/21)

**PHYWE**  
excellence in science

It has to be kept in mind that the multimeter does not detect power fluctuations at frequencies exceeding some Hertz. In all cases the laser power first rises with increasing discharge current as might be expected because the discharge supplies for the laser population inversion. The intensity of the emitted uncoherent light from the discharge increases, too. But while the uncoherent light gets always more intense with increasing discharge current, the coherent light intensity begins to decrease at some point – more so, if the intra-cavity light intensity is not high.

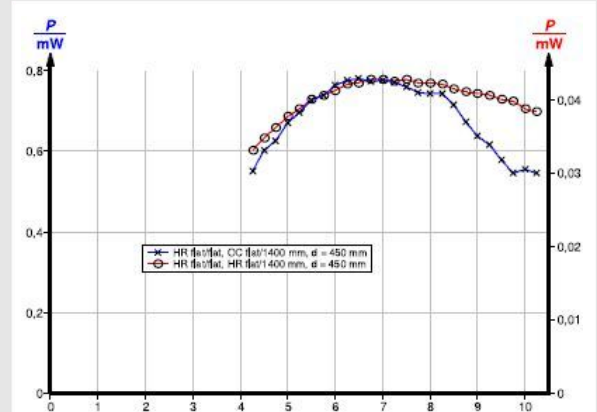

Comparison of output dependency on current for same resonator geometry but with HR or OC mirror.

## Evaluation (17/21)

**PHYWE**  
excellence in science

This is because the discharge current density gets unstable at a certain current density value for a specific tube geometry and gas pressure. Gas discharges generally have a negative resistance so the current has the tendency to contract to filaments if there are no damping processes to inhibit this. There is a characteristic formation time for the filaments.

If the time the gas particles need to pass the discharge space is smaller than this filament formation time, the filament formation gets damped out. The passing time of the gas particles is determined by thermal and turbulent diffusion time constants. The onset of discharge instability can be detected as noise on the laser output signal and occurs around 7 mA with the tubes in use in this experiment.

The rising line width of the laser transition with rising temperature and pressure can enable more modes to oscillate, if the cavity configuration allows this. So the drop of intensity for high discharge currents is less, if many modes are present.

## Evaluation (18/21)

It is also less if the intra cavity light intensity is high, because then saturation for a mode can be reached with lower gain. In case of few or weak, that is low-gain, modes the laser intensity gets reduced for higher temperatures even before onset of discharge instability because the density of atoms with the adequate velocity for a specific mode frequency sinks for broader velocity distribution in case of higher medium energy per atom.

This may be so though the density of atoms per volume may not sink in case of confined gas where the pressure rises with rising temperature.

## Evaluation (19/21)

### Task 6

With the grating of 600 lines/mm is  $\lambda = 1.67 \mu\text{m}$ . shown but is proportional to the inverse beam waist radius.

In the figure is the equation for the line of best fit for the red light

$$y = 0.420 z - 1.048$$

and for the green light

$$y = 0.345 z - 2.427$$

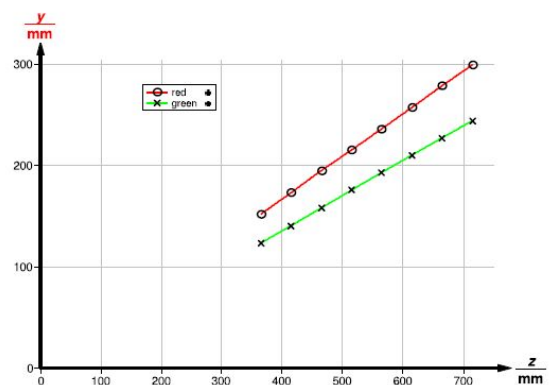

Plot of the measurement results.



## Evaluation (20/21)

so the angles are  $\alpha = 22.8^\circ$  for the red and  $\alpha = 19.0^\circ$  for the green light.

This yields with  $l = 1.67 \mu\text{m}$  a wavelength of  $0.645 \mu\text{m}$  for the HeNe laser and of  $0.544 \mu\text{m}$  for the frequency doubled green alignment laser.

The measurement error of 2 % compared with the literature values of  $0.633 \mu\text{m}$  for the HeNe laser and  $0.532 \mu\text{m}$  for the green laser is due to length measurement accuracy of less than 1 mm with measured lengths some hundred mm.

## Evaluation (21/21)

Drag the words into the correct boxes

He-Ne lasers use an electric  to excite the atoms of the . This process is known as electrical  and is normally used in  lasers.

Helium-neon laser is:

 a continuous laser beam a four-level laser a three-level laser a pulsed laser

Slide

Score/Total

Slide 126: Multiple tasks

0/6

Total Score

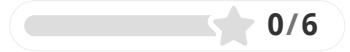

 Show solutions

 Retry