

Michelson interferometer



Physics

Light & Optics

Diffraction & interference



Difficulty level

-



Group size

-



Preparation time

-



Execution time

-



General information

Application



Aerial view of the Laser Interferometer Gravitational-Wave Observatory (LIGO) detector in Hanford, WA

Michelson's interferometer represented an immensely important instrument leveraging interference phenomena, to have wide utility. An interferometer system measures the change in distance by counting the number of wavelengths of light, which is known with great accuracy, seen by detection optics.

It allows for extremely precise determination of distances, characterization of spectral bandwidth, the study of the refractive index of gases and transparent media, the characterization of the quality of optical elements, and more. LIGO, a large Michelson interferometer, is the leading method for the direct detection of gravitational waves. It uses two very large laser interferometers with arms 4km long, located in two different places 3000km apart.

Other information (1/2)

PHYWE
excellence in science

Prior knowledge



Interference occurs, when two light beams superpose to form a resultant wave of a greater, lower or same amplitude. The two waves must be coherent and emit the same wavelength.

Scientific principle



In Michelson interferometer, a coherent light beam is split into two beams of equal intensity, that travel in different optical paths, which are then recombined to produce interference.

Other information (2/2)

PHYWE
excellence in science

Learning objective



In the Michelson arrangement, interference will occur by the use of two mirrors. The wavelength is determined by displacing one mirror using the micrometer screw.

Tasks



Determine the wavelength of light of the experimental laser.

Safety instructions

PHYWE
excellence in science



- The common rules of safe experimentation in scientific education apply in this experiment.
- The generally applicable rules for handling lasers according to the ANSI and IEC Laser Classification must be considered.
- Do not see directly into the laser beam and reflected beam. Always wear the appropriate laser safety eyewear (goggles) when the exit aperture of the laser is uncovered.
- Use suitable screening to isolate the area around the laser and avoid unwanted reflections.

Theory (1/4)

PHYWE
excellence in science

If two waves of the same frequency ω but of different amplitude and different phase impinge on one point, they are superimposed, or interfere, so that:

$$y = a_1 \sin(\omega t - a_1) + a_2 \sin(\omega t - a_2)$$

The resulting wave can be described as

$$y = A \sin(\omega t - a)$$

with the amplitude

$$A^2 = a_1^2 + a_2^2 + 2a_1a_2 \cos \delta$$

and the phase difference $\delta = a_1 - a_2$

Theory (2/4)

In a Michelson interferometer, light is split up into two beams by a half-silvered glass plate (amplitude splitting), reflected by two mirrors, and passed again through the glass plate to produce interference phenomena behind it.

A lens is inserted between the light beam and the glass plate so that the light source lies at the focal point, since only enlarged light spots can exhibit interference rings.

If the actual mirror M_2 is replaced by its virtual image, which is formed by reflection at the glass plate, a point P of the real light source is formed as the points P' and P'' of the virtual light sources L' and L'' .

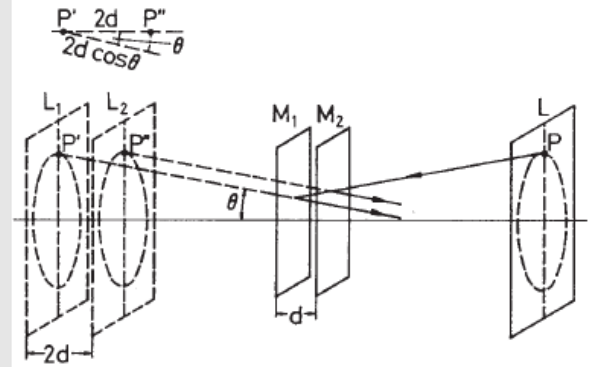

Formation of circles on interference.

Theory (3/4)

Based on the different light paths, the phase difference is defined as

$$\delta = \frac{2\pi}{\lambda} 2d \cos \theta \quad (2)$$

where λ is the wavelength of the light used in the experiment.

The intensity distribution $a_1 = a_2 = a$ for according to (1) is:

$$I A^2 = 4a^2 \cos^2 \frac{\delta}{2} \quad (3)$$

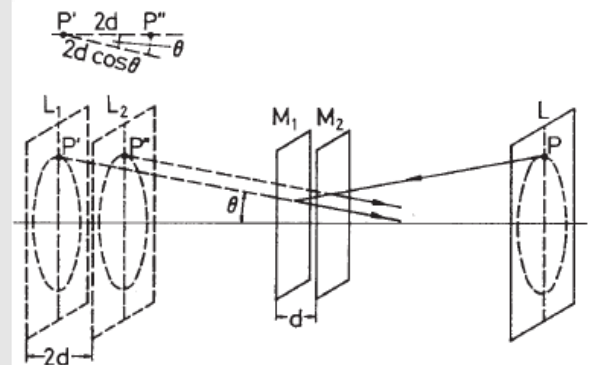

Formation of circles on interference.

Theory (4/4)

Maxima thus occur if δ is a multiple of 2π , i.e. from equation (2), if

$$2d \cos \theta = m\lambda; \quad m = 1, 2, \dots \quad (4)$$

i.e. circles are produced for a fixed value of m and d since θ remains constant.

If the position of the movable mirror M_1 is changed so that d , for example, decreases, then according to equation (4) the diameter of the ring will also decrease since m is fixed for this ring. A ring thus disappears each time d is reduced by $\lambda/2$. The ring pattern disappears if $d=0$.

If M_1 and M_2 are not parallel, curved bands are obtained which are converted to straight bands when $d=0$.

Equipment

Position	Material	Item No.	Quantity
1	Michelson interferometer	08557-00	1
2	Diode laser, green, 1 mW, 532 nm	08764-99	1
3	Lens, mounted, f +20 mm	08018-01	1
4	Lensholder for optical base plate	08723-00	1
5	Slide mount for optical bench expert, h = 30 mm	08286-01	3
6	Optical bench expert l = 600 mm	08283-00	1
7	Base for optical bench expert, adjustable	08284-00	2
8	Screen, metal, 300 x 300 mm	08062-00	1
9	Barrel base expert	02004-00	2
10	Digital array camera	35612-99	1
11	Lens holder	08012-00	1
12	Lens, mounted, f -50 mm	08026-01	1
13	Threaded pin DIN914 A1 M4x16	152649	1
14	HANDLE M4X140 PN11101 STVN	152644	1



Setup and procedure

Setup (1/3)

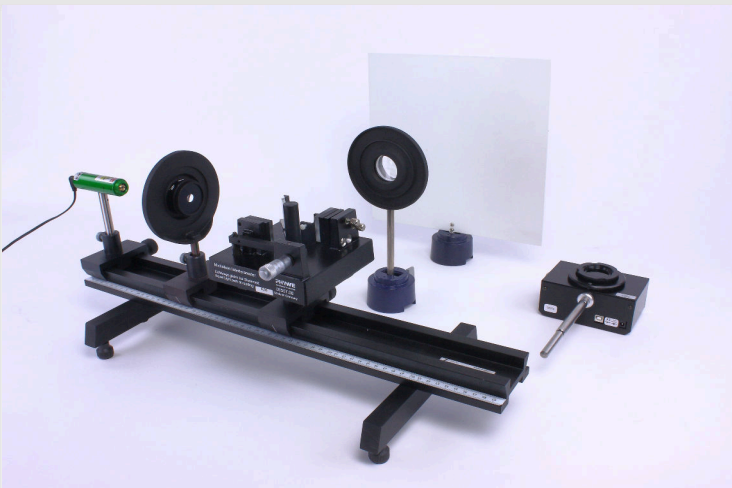

Experimental set-up for measuring wavelengths with the Michelson interferometer

- Laser, lens and Michelson interferometer are mounted on the optical bench at separate positions, which are 3 cm, 17 cm and 33 cm respectively.
- Darken the room when performing the experiment.

Setup (2/3)

PHYWE
excellence in science

- In order to obtain the largest possible number of interference fringes, the two mirrors of the interferometer are first adjusted (remove lens from optical bench when doing this). The laser beam strikes the half-silvered mirror at an angle of 45° splitting the beam. The resulting two beams are reflected by the mirror and impinge on the screen.
- By means of the two adjusting screws fitted to one of the mirrors, both points of light are made to coincide. If the lens is placed in the light beam, the points of light are enlarged and the interference patterns are observed on the screen (bands, circles).

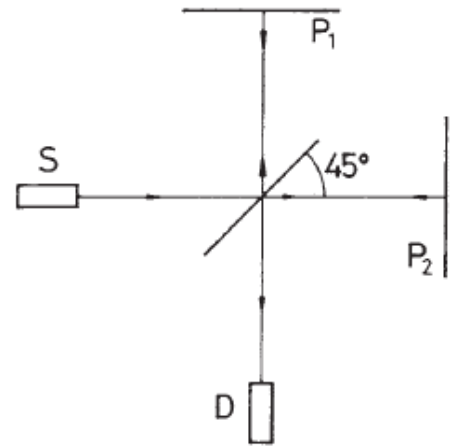

Michelson interferometer set up

Setup (3/3)

PHYWE
excellence in science

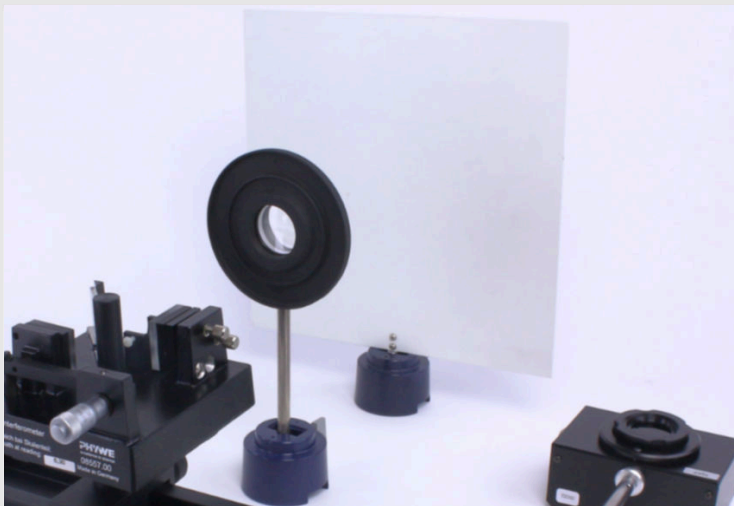

Placing the observing lens

- By careful readjustment, an interference image of concentric circles will be obtained. A second lens on a barrel base placed between the interferometer and the screen will enlarge the interference image on the screen and help with this readjustment.

Procedure

- To measure the wavelength, the micrometer screw is turned to any initial position at which the centre of the circles is dark. The micrometer screw is now further turned in the same direction and the light-dark periods produced are counted.
- The distance travelled by the mirror must be read off on the micrometer screw and divided by ten (lever reduction 1:10).
- Should the central point of the circles move outside the light spot area, a readjustment has to be performed.

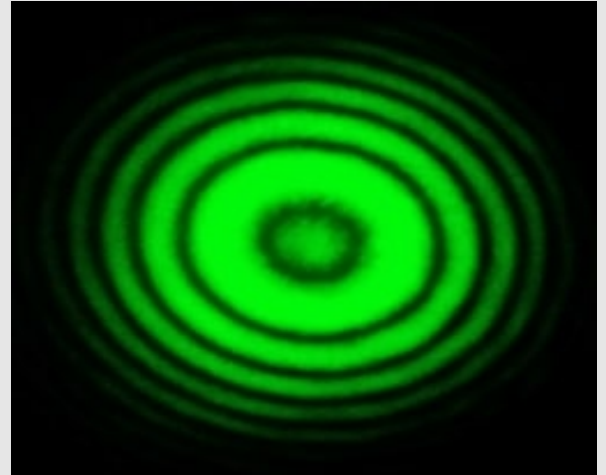

Interference rings using the Michelson interferometer

Evaluation (1/3)

No.	d / mm	m	λ/nm
1			
2			
3			
4			

$\bar{\lambda} =$ _____

Determination of wavelength for the incident laser beam

To calculate wavelength, a large amount of ring changes need to be counted (e.g. 500), and the corresponding mirror displacement needs to be measured. Then the laser wavelength can be determined by using Equation (4).

Figure out a relationship between the change in mirror position, the number of fringe shifts in the interference pattern, and the wavelength of the light. Calculate the wavelength and your uncertainty

Evaluation (2/3)

PHYWE
excellence in science

What is the purpose of a half-silvered mirror?

- Light reflects at 90 degree
- Light is reflected and transmitted into two beams
- It creates an interference pattern

✓ Check

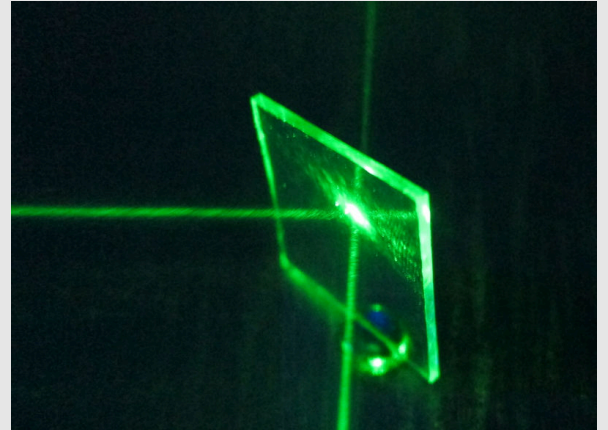

Aluminum coated beam splitter

Evaluation (3/3)

PHYWE
excellence in science

Describe how does a Michelson interferometer work?

At the half-silvered mirror, the incident light beam is separated into two partial waves with the same . The reflected and transmitted beams travel along different . When the mirror in one arm of the interferometer moves a distance of , the path difference changes by , and each fringe in the interference pattern moves to the position previously occupied by the adjacent fringe.

amplitude

optical paths

λ_0

$\lambda/2$

✓ Check

Slide	Score/Total
Slide 17: Half-silvered mirror	0/1
Slide 18: Michelson Interferometer	0/4

Total Score  0/5

 Show solutions

 Retry