

## STUDYING THE CONVERSION OF RENEWABLE ENERGY



ref. CONVERTYS  
 ref. CHARGEOL

### EDUCATIONAL OBJECTIVES

- Study of the conversion of the electrical energy from 3-phase to single-phase.
- Make some measurements with a clamp-on ammeter.

TEACHING RESOURCES STUDENT & TEACHER

### Proposed Practical Works

- Understanding of the wiring diagram.
- Sizing of the electrical components related to the voltage and the power.
- Reading of currents and voltage in different points of the circuit.
- Calculation of powers.
- Calculation of electrical efficiencies.

These converters operate on the same principle as an industrial model. They treat the electrical power supplied by a wind turbine. The output cannot be synchronized with the network but can be used in isolated site.

### TECHNICAL CHARACTERISTICS

- The converter's synoptic, printed on the front, facilitates location of the components and measurement points.
- The three-phase voltage from the wind turbine is applied to CONVERTYS or CHARGEOL through 4 safety terminals 4mm dia. The wind turbine-to-converter interconnection is made using laboratory leads.
  - CONVERTYS : Inputs between 375 and 460V three-phase.
  - CHARGEOL : Inputs between 80 and 120V three-phase.
- A main switch located on the top of the box, starts and stops the converter's power supply.
- Safety terminals 4mm diam. located between each component enable the voltages and currents to be measured at each conversion step.
- A thermal-magnetic circuit-breaker protects the transformer primary against any overload.
- Output converter 500W/230V.
- A differential circuit-breaker 30mA protects the output to the use network cabled according to neutral system TT.

Unit on casters dimensions: 700 x 500mm. Height 355mm

### CONVERTYS IS SPECIALLY MADE TO WORK WITH EOLYP CHARGEOL IS SPECIALLY MADE TO WORK WITH EOLYS-500

#### List of Practical Works achievable with each set:

- Principle of functioning
- The 3-phase voltage delivered by the wind turbine is galvanically separated by an isolation transformer, and then rectified by a Graetz bridge.
- This DC voltage is transformed by a DC/AC converter in an alternative voltage 230V (50Hz) / 500VA
- In case of exceeding of this power, the converter automatically offloads the output, switch on an overload indicator light, and resets 15 seconds after load reduction.

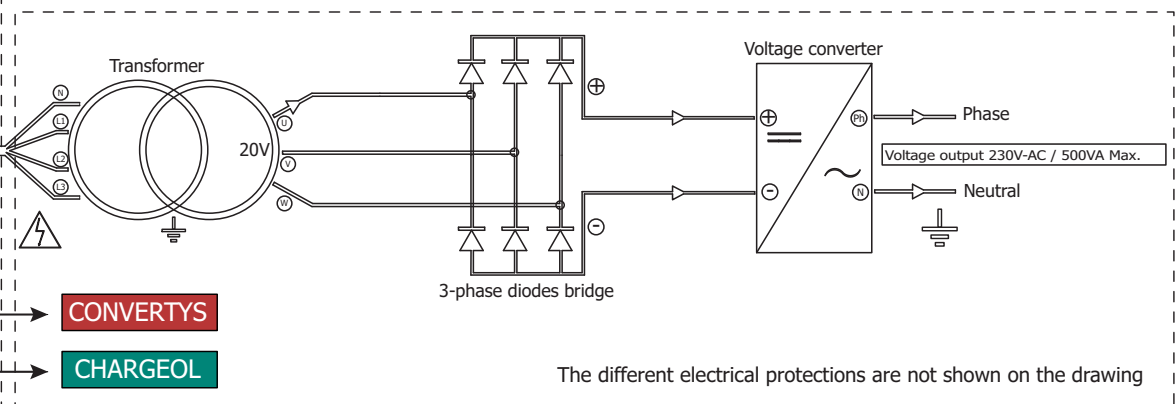
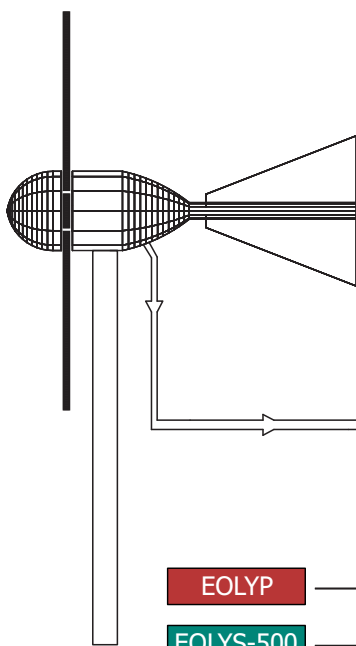

EOLYP →  CONVERTYS  
 EOLYS-500 →  CHARGEOL

The different electrical protections are not shown on the drawing