

PHYWE Systeme GmbH & Co. KG
Robert-Bosch-Breite 10
D-37079 Göttingen

Telefon +49 (0) 551 604-0
Fax +49 (0) 551 604-107
E-mail info@phywe.de
Internet www.phywe.com

Operating instructions

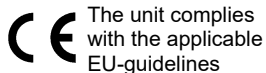

Fig. 1: Inclined plane, equipment set complete, 11301-10

TABLE OF CONTENT

- 1 SAFETY PRECAUTIONS
- 2 PURPOSE AND CHARACTERISTICS
- 3 FUNCTIONAL- AND OPERATING ELEMENTS
- 4 HANDLING
- 5 EXPERIMENTS
- 6 TECHNICAL DATA
- 7 LIST OF EQUIPMENT
- 8 WASTE DISPOSAL

1 SAFETY PRECAUTIONS



Caution

- Carefully read these operating instructions completely before operating this instrument. This is necessary to avoid damage to it, as well as for user-safety.

2 PURPOSE AND CHARACTERISTIC

With the aid of the compact device, forces that keep a body in equilibrium on this plane can be investigated for different angles of inclination of an inclined plane without time-consuming setup and adjustment work. The basic relationship between force, displacement, stroke and work for simple machines can be worked out.

A rolling body used as a measuring object has the advantage that the lines of attack of all acting forces intersect at one point, the center of gravity. On the one hand, this avoids undesirable torques, and on the other hand, the physical facts can be presented more simply and transparently.

For the direct determination of the test geometry, the device is equipped with two scales and an angle scale, so that the continuously adjustable inclination angle of the plane can be read off directly, but also the angle function \sin , which is relevant for the inclined plane, can be determined as a quotient of final height to path length by direct reading off the two scales.

With the aid of the two force gauges, the corresponding force components parallel and perpendicular to the rolling plane can be taken.

3 FUNCTIONAL AND OPERATING ELEMENTS

The inclined plane has the following parts or functional elements (see Figs. 2, 3).

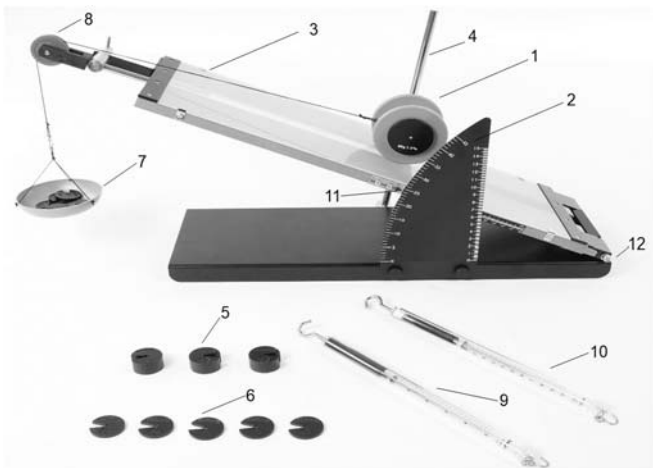

Fig. 2

1. Rolling body (11301-01)
2. vertical plate with angle scale. Two knurled screws with angle scale. The knurled screws are used for fastening to the base plate.
3. inclinable track with demonstration cm graduation for realization of inclined plane. The track can be rotated around a hinge (12) and can be adjusted in height by means of a sleeve with locking screw on the threaded stem (4).
5. slotted weights, 50g
6. slotted weights, 100g
7. bowl for slotted weights
8. pulley with guide slot for a thread, which can be attached to the pulley body (1) and the shell.
9. Spring balance 5N
10. Spring balance 5N
11. pointer for indication of the angle of inclination

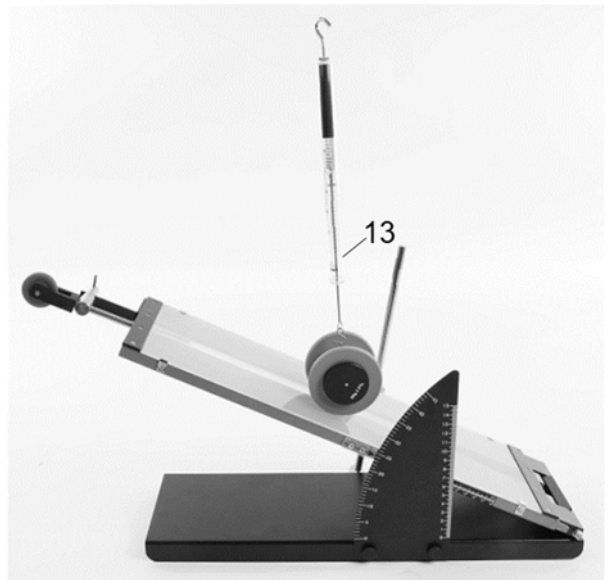

Fig. 3

13. The second spring balance 5N can be attached directly to the roller body to measure the vertical force component.

4 HANDLING

The inclined plane can be disassembled if necessary and stored in a space-saving manner. Proceed as follows to assemble the inclined plane:

- Loosen the track (3) at the threaded stem (4) and fold it down. If necessary, unscrew the threaded stem.
- Attach the supplied thread to the shell. Select the length of the second thread so that the rolling element is centered on the roller track.
- to measure the force components, two spring balances can be attached directly to the rolling element.

5 EXPERIMENTS

5.1 Measurement of the path component F_s (slope down force)

First, the weight force F of the rolling element with and without additional masses is determined (spring balance 5 N). Then the force can be measured by hand parallel to the roller track. The component F_s is determined for different angles of inclination or heights h , so that the relationships

$$F_s = F \cdot \sin \alpha \quad \text{bzw.} \quad F_s = F \cdot \frac{h}{l} \quad (l = \text{Bahnlänge})$$

can also be verified by graphical application, if necessary.

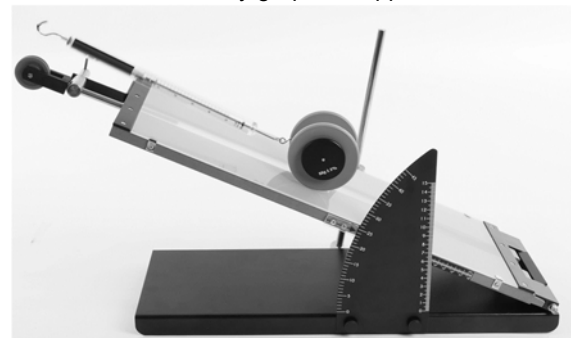

Fig. 4

5.2 Decomposition of the weight force of a body on the inclined plane (slope force F_s and normal force F_n)

The rolling element (1) has two fastening hooks at the center of gravity. Here it is possible to attach both force gauges in order to measure the corresponding force component in each case.

It must also be ensured that the direction of application of the tensile force is exactly perpendicular to the path. With correct adjustment, the force component F_s must have the same values for corresponding inclination angles of the plane as in the case of the overlying rolling element (Experiment 5.1). For different angles of inclination or heights h , the rolling element can now be given the relations

$$F_n = F \cdot \cos\alpha \quad \text{bzw.} \quad F_n = F \cdot \frac{x}{l}$$

can be verified. Here x is the projection of the path length l onto the horizontal.

Since the rolling body is kept in equilibrium in this case by two forces perpendicular to each other, the experiment also results in the decomposition of the weight force F into two perpendicular components whose direction varies by changing the angle of inclination.

6 TECHNICAL DATA

| | |
|---------------------------|----------------|
| Base plate | (520 x 155) mm |
| Vertical plate | (100 x 215) mm |
| Scale range | 0° - 45° |
| Plane length | 440 mm |
| Mass of rolling body | 50 g ± 2% |
| Mass of additional weight | 200 g ± 2% |

7 LIST OF EQUIPMENT

| | |
|---------------------------------------|----------|
| Inclined plane equipment set complete | 11301-10 |
| Inclined plane | 11301-02 |
| Rolling element | 11301-01 |
| Spring balance 5 N | 03065-04 |
| Slotted weights 10g | 02205-03 |
| Slotted weights 50g | 02206-03 |
| Fishing line 5m | 02089-01 |

8 WASTE DISPOSAL

The packaging mainly consists of environmentally-friendly materials that should be returned to the local recycling stations.



Do not dispose of this product with normal household waste. If this unit needs to be disposed of, please return it to the address that is stated below for proper disposal.

PHYWE Systeme GmbH & Co. KG
Customer Service
Robert-Bosch-Breite 10
D-37079 Göttingen

Telefon +49 (0) 551 604-274
Fax +49 (0) 551 604-246