

SOLAR CENTRAL UNIT WITH SUPERVISOR

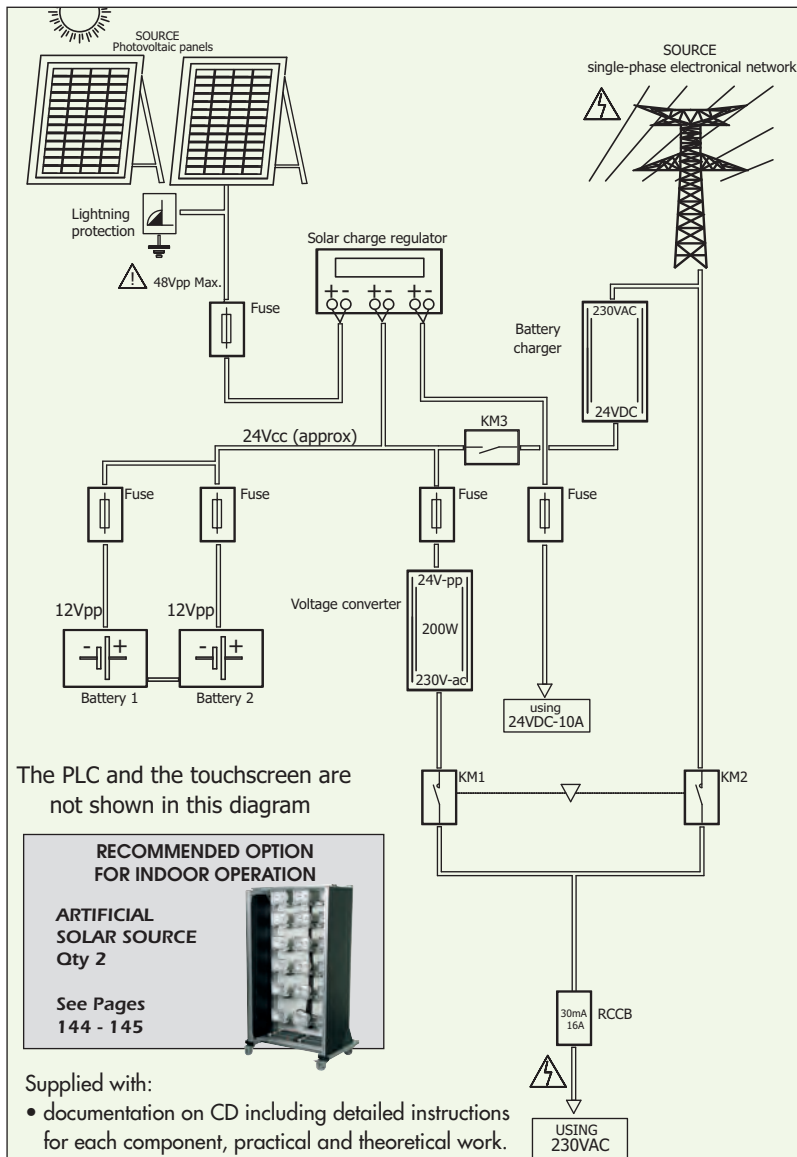

ref. SOLHAB

ref. SOLHAB-N Sold without panel.



RECOMMENDED OPTION FOR INDOOR OPERATION

ARTIFICIAL SOLAR SOURCE Qty 2

See Pages 144 - 145



Supplied with:

- documentation on CD including detailed instructions for each component, practical and theoretical work.
- Software for PLC programming.
- VIJEODESIGNER software for touchscreen programming.
- 2 photovoltaic panels with link cable

EDUCATIONAL OBJECTIVES

- Studying of a photovoltaic system in a isolated site.
- Creation of a PLC program.
- Creation of a supervision application of a touch screen.
- Using a clamp-on ammeter.
- Studying the efficiency of a photovoltaic system.

TEACHING RESOURCES STUDENT & TEACHER

Feasible practical works

- Theoretical work on the positioning of solar panels.
- Studying the sizing of photovoltaic components in a isolated site.
- Understanding of the wiring.
- Calculation of powers.
- Programming of the PLC and the touch screen.
- Producing or modification of a supervision application.

Possible scenarios

Alterable by the programming software of the PLC and the touch screen

- Using of the energy provided by the solar panels.
- Batteries recharging by the charger.
- Automatic sources switching.
- Use of solar energy during the day and electrical network at night.
- Use of the energy provided by the electrical network.

Technical characteristics

On the top surface:

- 1 main ON/OFF switch + 1 emergency stop button.
- 1 24VDC batteries charging switch.
- 1 touchscreen 3x4" colour QVGA, 320 x 240 pixels, Ethernet socket. Control interface between the user and the system, it displays electrical parameters necessary for the understanding of the functioning. It allows a simple and complete supervision, monitoring and control.
- 1 solar load regulator.
- 1 set of signalling indicator lamps.
- 2 synoptics / complete diagram of the system with terminals and indicator lamps.
- Safety terminals for 230V-AC use output.

On the side:

- 2 safety terminals for voltage input from the solar panel.
- 1 main isolating switch from the public network.
- 1 solar panel isolating safety switch
- 1 RJ45 Ethernet connector.

In the cabinet

- 2 batteries 12VDC-12Ah + 1 battery charger 24V.
- 1 pure sine inverter 24VDC/230VAC-50Hz - 300W.
- 1 PLC Ethernet.
- 1 analogue board 2 Inputs 0-10V/4-20mA and 1 Output 0-10V/4-20mA
- 1 4-port Ethernet coupler.
- 1 set of protection devices included 1 open door safety device.

Photovoltaic solar panel on tilting frame

- Useful surface area of the cells 1.5m².
- Open circuit voltage: 46V DC, Optimum operating voltage: 37V DC
- Short-circuit current: 6.3A
- Optimum operating current: 5.7A
- Maximum power: 215Wc (variation of ± 10% depending on the series)
- Device for measuring the tilt angle
- Tilt adjustable from 5° to 70°
- Light and easy to move.

Dimensions:

Folded position: 1600 x 800 x 100mm (± 10% depending on the series)

System power by power cord. 2P+E. 230VAC 50/60Hz

